

Operating Manual

20 Series Dual Pass Binary Gas Analyzer

20 Series: 120 V, 50/60 Hz

22 Series: 230 V, 50/60 Hz

**November 2024
Rev. 11**

**READ INSTRUCTIONS
BEFORE OPERATING**



DISCLAIMERS

The information in this document is subject to change without notice. This manual could include technical inaccuracies or typographical errors. Changes are made periodically to the information herein; these changes will be incorporated in subsequent revisions of the manual. GOW-MAC® Instrument Co. reserves the right to make improvements and/or changes to the product(s) and/or programs described in this manual at any time and without notice.

All information referred to and/or included in this report is current as of the original issue date of this manual. GOW-MAC® Instrument Co. makes no warranty or representation with respect to the accuracy of the information or with respect to the suitability of the use of such information outside GOW-MAC® Instrument Co., nor does GOW-MAC® Instrument Co. assume responsibility for any injury or damage which may result, directly or indirectly, from the use of such information.

This document contains proprietary information which is protected by copyright. All rights are reserved. No part of the document may be photographed, reproduced, or translated into another language without the prior written consent of GOW-MAC® Instrument Co.

The warranties made by GOW-MAC® Instrument Co. with respect to the product are voided if the product is not used and serviced in accordance with the instructions in this manual.

Please protect yourself and your employees by following these operating instructions. We encourage our customers to write or call for any additional information relative to the use or repair of this instrument.

TRADEMARK AND PATENT INFORMATION

®GOW-MAC is a registered trademark of GOW-MAC Instrument Co.
in the United States and other countries. (Reg. U.S. Pat. & T.M. office)

Other trademarks used herein are trademarks or registered trademarks of their respective owners.

TERMS AND CONDITIONS OF SALE

WARRANTIES 20 SERIES ANALYZERS SOLD BY GOW-MAC® INSTRUMENT CO. ARE WARRANTED FOR A PERIOD OF ONE YEAR AGAINST DEFECTS IN MATERIALS AND WORKMANSHIP. THE TERMS OF THIS WARRANTY ARE AS FOLLOWS:

1. The warranty period begins with the shipping date of the equipment to the original purchaser.
2. Certain parts such as batteries, fuses, glass accessories, septa, columns, etc., are expendable in normal use, and their service life is unpredictable. Such items are not covered by this warranty.
3. Filaments of thermal conductivity detectors are not covered by this warranty.
4. Hydrogen Palladium Tubes are not covered by this warranty.
5. All requests for service or repair under this warranty must be received within the warranty period by GOW-MAC® or its authorized representative. All repairs are made at GOW-MAC plants or at the office of authorized representatives.
6. All repairs, adjustments, and other services under this warranty shall be performed free of charge to the purchaser. However, warranty service and repairs shall be limited to equipment malfunctions which, in the opinion of GOW-MAC®, are due or traceable to defects in original materials or workmanship. Instrument malfunctions caused by abuse or neglect of the equipment are expressly not covered by this warranty.
7. Instrument parts which have been repaired or replaced during the warranty period are themselves warranted only for the remaining unexpired portion of the original one-year warranty.
8. Repairs, adjustments, and service performed after expiration of the one-year warranty period shall be charged to the purchaser at the then current prices for parts, labor, and transportation.
9. This warranty attaches to the equipment itself and is not limited to the original purchaser. Unexpired portions of the warranty are thus transferable to subsequent owners.
10. GOW-MAC® expressly disclaims any liability to users of its products for consequential damages of any kind arising out of or connected with the use of its products.
11. Except as stated in Sections 1 through 8 above, GOW-MAC® makes no warranty, expressed or implied (either in fact or by operation of law), statutory or otherwise; and, except as stated in Sections 1 through 8 above, GOW-MAC® shall have no liability under any warranty, expressed or implied (either in fact or by operation of law), statutory or otherwise.
12. Statements made by any person, including representatives of GOW-MAC® which are inconsistent or in conflict with the terms of this warranty shall not be binding upon GOW-MAC® unless reduced to writing and approved by an officer of the Company.
13. This warranty shall be governed by the laws of the Commonwealth of Pennsylvania.

LIABILITY Buyer assumes all responsibility for warning and protecting its employees and independent contractors with respect to all hazards to persons and property in any way connected with the Equipment and the use thereof. Seller's liability for any claim of any kind hereunder, whether or not based on contract, tort (including negligence), strict liability, warranty, or any other grounds, shall not exceed the purchase price of the Equipment or the portion of the purchase price attributable to any part or parts of the Equipment in respect to which such claim is made. Seller shall not be liable for any special, indirect, incidental, or consequential damages. Without limiting the generality of the foregoing, Seller shall have no liability with respect to the results obtained by use of the Equipment, whether in terms of product condition, operating cost, general effectiveness, success or failure, or regardless of any statement made in any written proposal submitted by Seller. It is expressly understood that any technical advice furnished by Seller with reference to the Equipment is given gratis and Seller assumes no obligation or liability for the advice given or results obtained, all such advice being given and accepted at Buyer's risk. Each party hereby agrees to indemnify and hold the other party harmless from any actions, lawsuits, demands, claims, losses, expenses, costs, including but not limited to legal fees, and damages arising from the injury, illness or death of the indemnifying party's employees in any way related to the Equipment, whether or not such injury, illness, or death is claimed to have been caused by, resulted from, or was in any way connected with the negligence of the party to be indemnified.

PROPRIETARY INFORMATION Buyer agrees to maintain all proprietary information disclosed by Seller, including such proprietary information obtainable upon examination of the Equipment, in confidence and to refrain from any disclosure thereof to any third party (including any affiliate of Buyer), for any purpose, without the prior written consent of Seller. Buyer agrees to use said proprietary information solely for purposes of maintaining and operating the Equipment, and to refrain from any use thereof to design, construct, have constructed and/or operate any duplication or modification of the Equipment, or from any other use thereof, without the prior written consent of Seller.

IMPORTANT INFORMATION

These instructions are written for personnel operating the GOW-MAC® 20 Series Dual Pass Analyzer. Read and understand the safety precautions in this manual to become familiar with the safe practices for operating this equipment.

Dangers, Warnings, Cautions, and Notes

Dangers, Warnings, Cautions, and Notes appear throughout this manual. A sample of each statement appears below. Within each sample, a definition of the statement type and its purpose is given.



DANGERS alert you to an immediate hazard that causes serious injury or death and requires special precautions to be taken.



WARNINGS alert you to a potential hazard that causes serious injury or death *under certain conditions*.



CAUTIONS alert you to a non-immediate or potential hazard or an unsafe practice that presents a minor threat of personal injury or damage to equipment, data, or processes.



NOTES emphasize or remind you of an important piece of information.

Contents

1	Safety.....	9
2	Introduction.....	13
3	Specifications	15
4	Installation.....	17
5	Controls.....	21
6	Operation.....	27
7	Instrument Options	29
8	Trouble Shooting	31
9	Replacement Parts List.....	33
	Appendix A: 20 Series Purge Option.....	35



This chapter contains information to promote safety in the operation and maintenance of this equipment. It is not intended to supersede, replicate, or replace any safety documentation or procedures provided from or established by official safety sources.



Do NOT operate the GOW-MAC® 20 Series Dual Pass Gas Analyzer until you read and understand the operating, maintenance, and safety instructions included in this manual.

All persons involved with the operation of this equipment including plant engineering, operations, and management-must understand the potential hazards involved, and know and observe all required safety precautions.

Your safety and the safety of equipment, nearby facilities, and personnel require a proper safety attitude and emphasis on safe work procedures. This is the essence of any good safety program. If at any time you identify safety deficiencies, immediately correct them and bring them to the attention of management.

Before an accident can be prevented, it must be anticipated. Use pre-job discussions with your coworkers and supervisors to identify hazards and the means to avoid them. At your facility, various gases may exist in liquid and/or gaseous states. Familiarize yourself with the hazards associated with each gas found at your facility.



Read and understand the Safety Data Sheets (SDS) for the materials used with this equipment. All personnel who work in the vicinity of this equipment should read, understand, and follow all safety information contained in the SDS, in addition to following all government and facility safety regulations.

1.1 Basic Safety Requirements

The following safety guidelines apply at all times when working with the 20 Series Dual Pass Gas Analyzer:

- **Prevent electrical shock** — Unplug and remove the AC power cord from the rear panel before opening and working on the analyzer. Use tools designed for work on electrical equipment.
- **Prevent injury** — Always wear safety glasses and appropriate safety protection. Ensure that all tools and instruments used during installation and maintenance are in good condition. Be aware that high-velocity gas may be released at vents and safety relief valves.

Situations may develop for which no written procedures exist. Think carefully before acting. Know the function of each valve and switch, and its effect on the equipment. Carefully review all operating procedures before starting up this equipment to ensure knowledge and understanding.

1.2 Summary of Known Hazards

This equipment is designed to minimize your exposure to the process gases and other known hazards. Read and thoroughly understand all safety aspects of this system and its operation before operating or maintaining the equipment.

1.2.1 Electrocutation

Adherence to the following guidelines helps guard against electrical shock:

- For safety and proper performance, this analyzer must be connected to a properly grounded three-wire source of electrical power.
- Tampering or unauthorized substitution of components may adversely affect the safety of this instrument. Use only factory-approved components for repair.
- Before checking or replacing any chassis component, turn off the power and remove the AC power cord.

1.2.2 Pressure



Mishandling of gas cylinders could result in death, serious injury, or property damage. Handle and store gas cylinders with extreme care and in accordance with manufacturer's instructions.

Sudden or uncontrolled release of pressurized gas can cause serious injury. The hazards of high pressure can be avoided through careful inspection and handling of cylinders and equipment with proper regulation. Read and understand the SDS for the process gases used before operating this analyzer. For more detailed information on the precautions and safe practices to follow when handling cylinders, obtain and read CGA pamphlet P-1, *Safe Handling of Compressed Gases in Cylinders*.

1.2.3 Fire Prevention for Flammable Samples

- Care should be taken to locate the instrument, gas vents, and other connections away from extreme heat and other ignition sources. (see Section 4.2)
- Ensure fire suppression systems are in working condition.
- When necessary, installation of flame arrestors on sample vents may prevent the spread of fire.

1.3 Safe Repair Procedures

Any repair work must be performed by a GOW-MAC service technician.

Ventilate working area to prevent any leaking supply gas from accumulating.

Vent all gases to the outside.

Vent all pressure relief valves out of enclosed areas. Piping must be properly sized to allow safety devices to operate according to specifications.

De-pressurize supply gas piping before working on it.

1.4 General Precautions for Handling and Storing High Pressure Gas Cylinders

Compressed gases have properties that can cause serious accidents, injuries, and even death if proper precautions and safety practices are not followed. Therefore, during handling and use of these gases, be certain to use applicable safety precautions described by your local compressed gas supplier, the Compressed Gas Association, and/or O.S.H.A. regulations.

1. Read the label on all cylinders **BEFORE** using to identify the cylinder contents. If the label is illegible, return the cylinder to the supplier. **DO NOT ASSUME THE CONTENTS.**
2. Secure cylinders in storage and in use to an immovable structure to prevent accidental falling or movement. Read the relevant safety codes.
3. Store or move cylinders **ONLY** in the vertical position. **DO NOT** move or transport cylinders with regulators attached.
4. Store cylinders in a well ventilated area away from heat or ignition sources.
5. When installing tubing, provide **ONLY** approved, adequate pressure reducing regulators and pressure relief devices to prevent over-pressurizing of tubing and equipment.
6. Never drop cylinders or permit them to strike each other violently.
7. Cylinders may be stored in the open but, in such cases, should be protected against extremes of weather and from damp ground (to prevent rusting). In areas where extreme temperatures are prevalent, store cylinders in the shade.
8. The valve protection cap should be left on each cylinder until cylinder has been secured against a wall or bench, or placed in a cylinder stand and is ready for use.
9. Avoid dragging, rolling or sliding cylinders even for a short distance. Move cylinders by using a suitable hand truck.
10. Never tamper with safety devices in valves or cylinders.
11. Do not store full and empty cylinders together. Serious suck-back can occur when an empty cylinder is attached to a pressurized system.
12. No part of a cylinder should be subjected to a temperature higher than 52 °C (125 °F). Do not permit flame to come in contact with any part of a compressed gas cylinder.

2 Introduction

The GOW-MAC 20 Series Dual Pass Thermal Conductivity Analyzer was developed for the determination of binary gas mixes and gas purity measurements. This analyzer compares the difference in the thermal conductivity between the sample and reference gases which are exposed to the detector elements.

Four sensing elements are connected to form an electrical Wheatstone bridge circuit. These elements are miniature Rhenium-tungsten filaments (supplied as standard; yours may be different - check your order) which are mounted in a metallic cell block. A diffusion type thermal conductivity cell is used in this analyzer. This cell contains a sample and reference gas flow geometry. Two filaments are in the sample flow (channel) and two filaments are in the reference flow (channel). The elements are heated by an electrical current from a constant voltage dc power source.

To operate the instrument, the reference gas must be passed through **both** the sample and reference channels. When a sample gas of different composition is introduced into the sample system, a change in the rate of heat loss will occur. This change will cause the filament resistance to change, causing the Wheatstone bridge to unbalance. The output voltage from the detector cell is fed into a calibrated digital meter. The gas analysis can be read directly from the meter display.

Specifications



NOTE

This instrument may have been customized for your requested application. Please check the supplied QC Documentation for specific information regarding your instrument.

Power Requirements	20 Series: 115 V AC, 60 Hz 22 Series: 230 V AC, 50 Hz
Dimensions	Case: 10.25" H x 10.25" W x 17.25" D Panel Mount Flange: 12.4" H x 14.1" W
Net Weight	approximately 30 lbs.
Gas Connections	1/8" o.d. tubing
Operating Temp. Range	ambient - 120 °F (ambient - 49°C)
D.C. Power Supply	3-20 Volts @ 300 mA
Power Supply Line Regulation	0.5%
Readout	Digital Meter with 4-20 mA Output and High/Low alarms (standard) Digital Meter with Voltage Output, full range concentration = 1.0 V (optional) Recorder, 0-5 millivolts
Accuracy	3% of full scale on meter; 1% on recorder
Sensitivity	Equivalent to 2% in air in helium
Gas Flow Rate	
Diffusion TCD	0.5 scfh operating 0-2 scfh flowmeter range
Semi-diffusion TCD (Option 206 only)	50 ccpm operating 0-130 ccpm (Air) flowmeter range
Pressure Required (Sample, Reference, and Calibration Gases)	6" H ₂ O minimum to 100 psig

Specifications and features will vary depending upon system configuration and are subject to change without notice. The above specifications are established during design, but are not to be construed as test criteria for every product.

Installation

4.1 Unpacking - Inspection

- 4.1.1 When unpacking the instrument, check it carefully for evidence of shipping damage or rough handling. Check to ensure that all components ordered have either been supplied or back-ordered. Notify the Company of any discrepancies. The packing box should be retained for use if the instrument needs to be returned to the factory for repair or modification. GOW-MAC does not supply field service. ALL repairs are made at Bethlehem, PA or by an authorized GOW-MAC representative.
- 4.1.2 Remove all plastic and/or paper shipping caps and restraints before operating.

4.2 Location

- 4.2.1 The 20 Series Dual Pass Gas Analyzer should be placed in a location that is secure, vibration-free, protected from abrupt temperature changes (operating ambient temperature range is ambient - 120 °F (ambient - 49 °C), and drafts. Such changes may upset stability in the course of an analysis or calibration.
- 4.2.2 Enough adjacent tabletop space should be allowed for the installation of recorders, integrators, computers, etc. Allow sufficient space on all sides of the analyzer for easy access.
- 4.2.3 Make sure that there is adequate space for the installation of the gas cylinders. Cylinders should be securely fastened to the wall or table per CGA and/or O.S.H.A. regulations.



READ CGA AND/OR O.S.H.A PROCEDURES FOR PROPER HANDLING OF COMPRESSED GAS CYLINDERS.

- 4.2.4 An electrical outlet (AC) should be near the location where the analyzer will be installed. If the outlet is not a 3-pin type, make sure that a good ground connection is available since a good ground is necessary for proper operation. The AC outlet should be connected to a circuit that is not heavily loaded with other electrical equipment. Input voltage to the analyzer should be steady for optimum operating stability.

If the AC line voltage varies, consideration should be given to the installation of a stabilizing transformer at the AC outlet.

4.3 Power Requirements

- 4.3.1 The 20 Series Dual Pass Gas Analyzer requires a 120 volt/50-60 Hz power source capable of providing up to 10 amps.

- 4.3.2 The 22 Series Dual Pass Gas Analyzer requires a 230 volt/50-60 Hz power source capable of providing up to 5 amps.



MAKE SURE ALL SWITCHES ON FRONT OF THE INSTRUMENT ARE IN THE "OFF" POSITION BEFORE PLUGGING THE INSTRUMENT IN. DO NOT PLUG IN UNIT AT THIS TIME.

4.4 Recorder Connection (if using)

- 4.4.1 Supplied with your GC is a recorder cable. Both ends of the cable terminate in three (3) spade terminals. Cable color is as follows: RED lead, positive (+); BLACK lead, negative (-); and SILVER (shield) lead, ground.

4.4.2 Connections

- a Connect one end of the recorder cable to the terminals located at the rear of the analyzer. Color connections should be made as follows:

BLACK lead to BLACK or NEGATIVE terminal
RED lead to RED or POSITIVE terminal
SILVER lead to GREEN or GROUND terminal

- b Connect the other end of the recorder cable to the proper terminals on the recorder or integrator.

4.5 Gas Connections (General)

- 4.5.1 The 20 Series Dual Pass Gas Analyzer requires the following gases equipped with ordinary two stage regulators:

- a. Zero Gas (also serves as Reference Gas)
- b. Span Gas (for calibration)
- c. Sample Gas

- 4.5.2 Tubing connections for the Zero, Span, and Sample gases are 1/8" compression fittings. Tubing connections for cabinet purge gas (if so equipped) are 1/4" compression fittings.

- 4.5.3 To prevent contamination of the analyzer and the detector by grease, oil, or chemical residue, the following procedure MUST be performed for purging all stainless steel tubing of possible contaminants PRIOR to connection to the analyzer:

- a. Cut desired tubing length with a hand-held tubing cutter. DO NOT use any cutting oils or motorized saws. Oils contaminate and saws create ruff edges and burrs.

- b. Use REAGENT GRADE solvents to wash and INSTRUMENT GRADE nitrogen or helium to dry tubing as follows:

		WASH	DRY
Step 1	100 mL	water	N ₂ or He
Step 2	100 mL	acetone	N ₂ or He
Step 3	100 mL	acetone	N ₂ or He



ABOVE PROCEDURE IS FOR TUBING LENGTHS OF 10'+. USE LESS SOLVENT FOR SHORTER LENGTHS. CAP ENDS OF TUBING UNTIL READY TO USE.



CLEANING SOLVENTS ARE EXTREMELY FLAMMABLE. USE CARE WHEN USING THESE MATERIALS. DO NOT EXPOSE THEM TO OPEN FLAMES OR SMOKING MATERIALS. DISPOSE OF SOLVENTS PROPERLY.

- c. All tubing should be free from moisture before installation.
- d. Make proper tubing connections (FIGURE 4-1).
- e. Make proper leak test on all fittings.



IT IS HIGHLY RECOMMENDED THAT A GOW-MAC GAS LEAK DETECTOR BE USED TO LEAK TEST THE SYSTEM. USE OF SOAP SOLUTION IS NOT RECOMMENDED SINCE IT WILL CONTAMINATE THE SYSTEM.

- 4.5.3 Connect ZERO and CALIBRATION gas cylinders to the ZERO and SPAN 1 inlets respectively at the rear of the instrument case. (Figure 4-1)
- 4.5.4 Connect the SAMPLE GAS to the SAMPLE GAS INLET located at the rear of the instrument case. (Figure 4-1) Note that the analyzer is equipped for ***either*** heated or unheated detector.

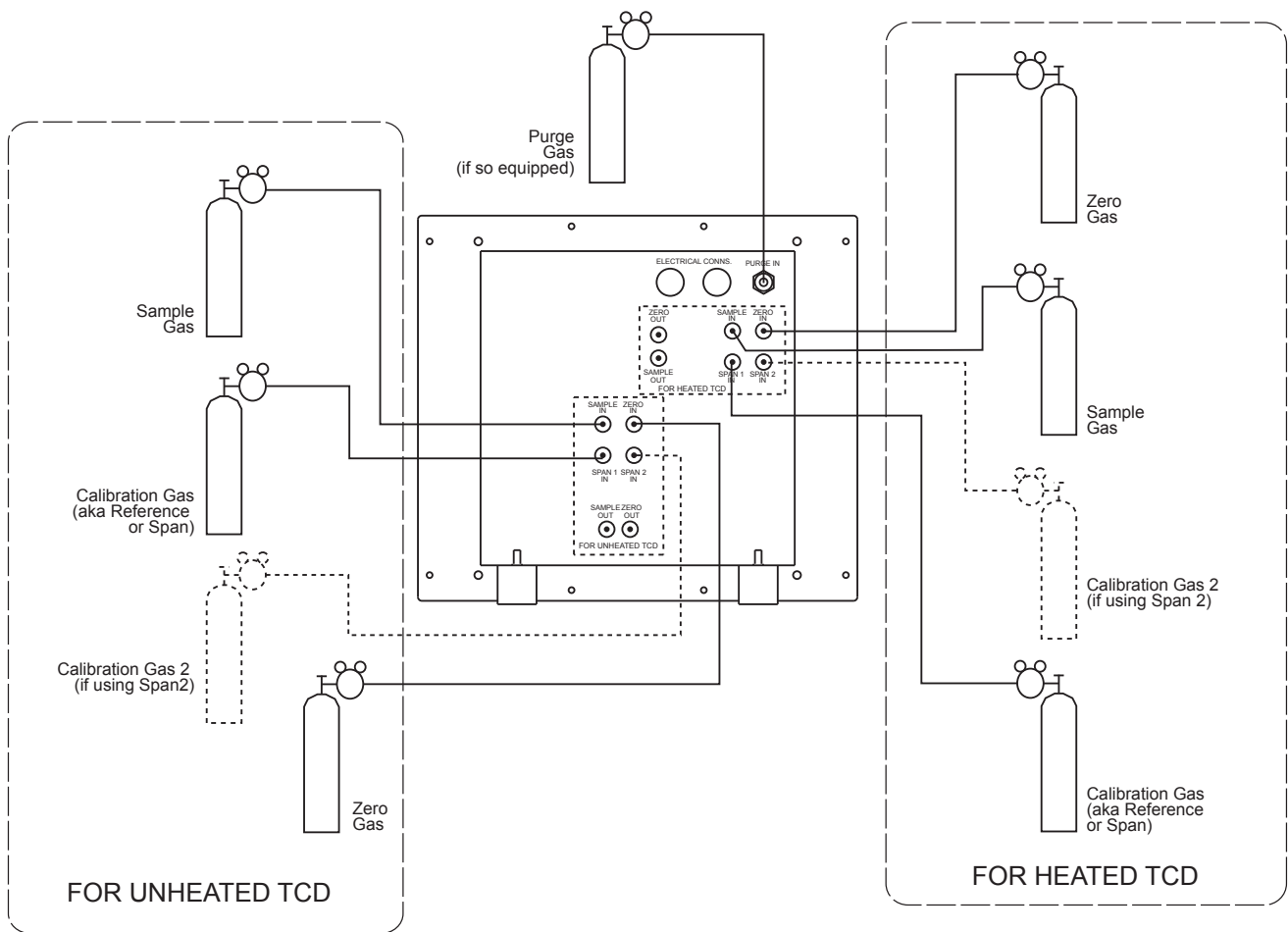

FIGURE 4-1

4.6 Purge Gas (if so equipped)

4.6.1 Refer to *Appendix A: 20 Series Purge Option* at end of this manual.

4.7 Leak Check

4.7.1 After all connections have been made and the gases are flowing, it is **VERY IMPORTANT** that they be tight and free from leaks. Leaks in the gas lines will cause baseline drift, noise, and will interfere with the detector (contamination).



A LEAK CHECK SHOULD BE MADE OF THE ENTIRE ANALYZER SYSTEM PRIOR TO INSTRUMENT OPERATION.

IT IS HIGHLY RECOMMENDED THAT A GOW-MAC GAS LEAK DETECTOR BE USED TO LEAK TEST THE SYSTEM. USE OF SOAP SOLUTION IS NOT RECOMMENDED SINCE IT WILL CONTAMINATE THE SYSTEM.

5.1 Front Panel (Figure 5-1)

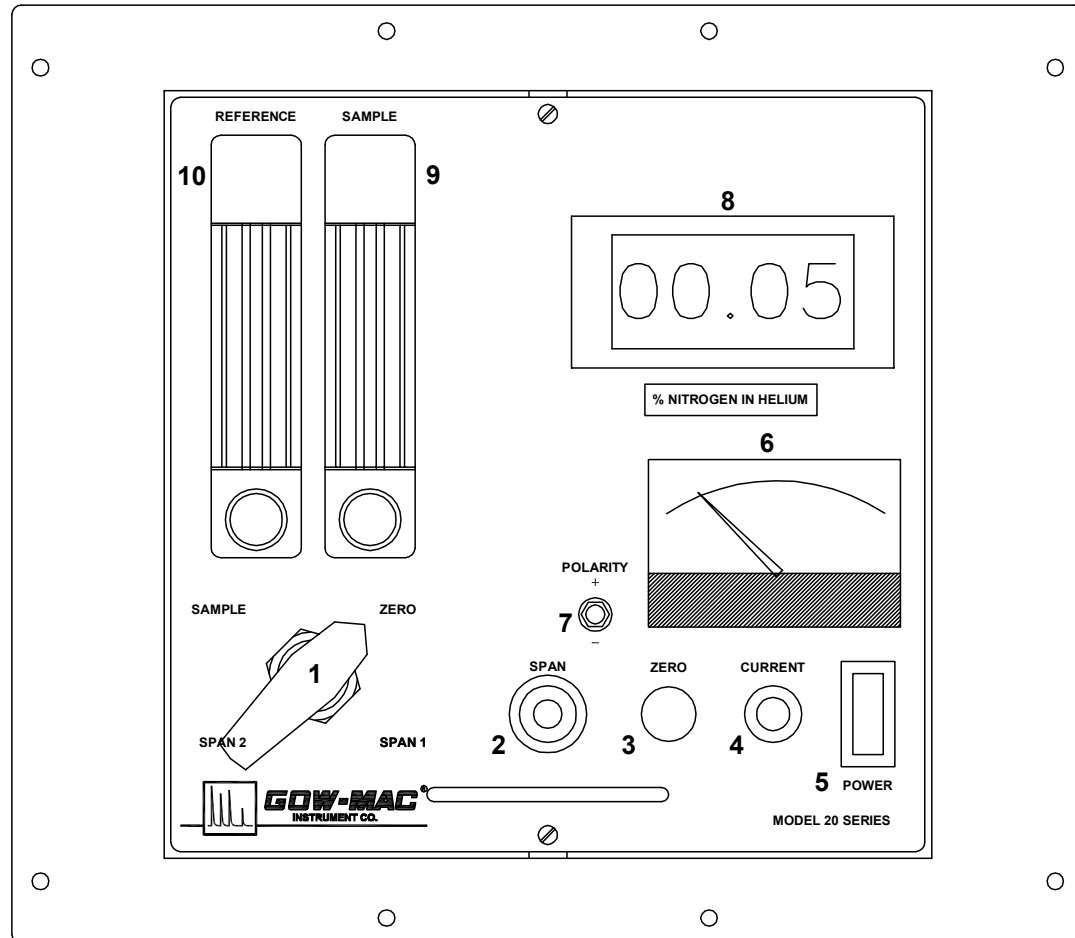

Figure 5-1 Front Panel

- 5.1.1 5-Way Selection Valve:
- 5.1.2 Span Knob (potentiometer): used for calibration with span gas
- 5.1.3 Zero Control: used for calibration with zero gas.
- 5.1.4 Detector Current Control: determines the sensitivity of the instrument. The higher the current, the more sensitive the instrument becomes. Chart 5-1 illustrates the maximum current as a function of TCD temperature. Recommended starting bridge setting is 100 mA for helium gas.

- Enter chart at 25 °C if the cell is unheated; 100 °C if cell is heated.
- Draw a vertical line to intersect with the curve for the applied gas. If gas is not shown on Chart 5-1, estimate the curve bases on the gas's thermal conductivity.
- Draw a horizontal line to the axis labeled "Bridge Current mA" to determine the maximum current.



The detector filaments can be damaged at currents above maximum.

**W, WX, W2, W2X,
AuW, AuW2, Ni, Ni2 Filaments**

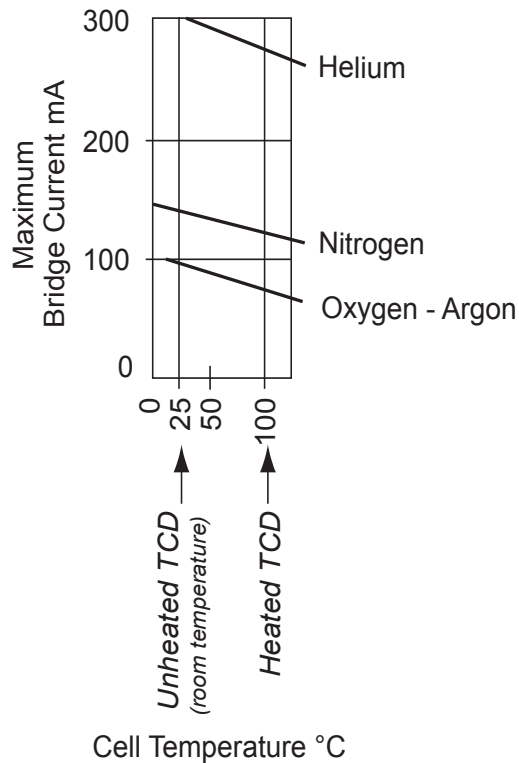

Chart 5-1

5.1.5 Power Switch: supplies line power to the analyzer when depressed and lit.

5.1.6 Current mA Meter:

- 5.1.7 POLARITY SWITCH: used when the signal on the digital meter display travels negative as the span/sample passes through the instrument. The polarity switch should be switched to the position (+ or -) so as to show a positive deflection when the span/sample has been introduced. The digital meter display will then travel in a positive direction. This will be dependent on the application.
- 5.1.8 Meter:
- Digital* — Depending on the application, displays the content of the sample stream in percent (%) or ppm.
- 5.1.9 Sample Rotameter: monitors flow rate of sample or calibration gases to the analytical cell.
- 5.1.10 Reference Rotameter: monitors flow rate of reference gas to the cell.

5.2 Rear Panel

5.2.1 For UNHEATED TCD (Figure 5-2)

- 5.2.1.1 Sample In: 1/8" compression fitting. Connect pressure regulated sample gas.
- 5.2.1.2 Zero In: 1/8" compression fitting. Zero gas is the major component of the 2-part mixture to be measured. Connect pressure regulated Zero gas.
- 5.2.1.3 Span 1 In: 1/8" compression fitting. Span 1 is a certified 2-part mixture to set the high end of the calibrated span. The span should be $\pm 20\%$ of the maximum sample concentration. Connect pressure regulated Span 1 gas.
- 5.2.1.4 Span 2 In: 1/8" compression fitting. Use of Span 2 is optional in single range applications unless a second calibration point is desired. In dual range configurations, Span 2 is the principle calibration point for Range 2 while Span 1 is the same calibration point for Range 1. Connect pressure regulated Span 2 gas.
- 5.2.1.5 Sample Out: 1/8" compression fitting. Sample, Zero, and Span gases exit the instrument thorough this port. Vent to atmosphere or to a vent manifold at constant atmospheric pressure.
- 5.2.1.6 Service Cord: This power cord should be plugged into a grounded receptacle. If a grounded receptacle is not available, use a three/two adapter but make sure that the ground lead is attached to the screw on the receptacle plate.
- 5.2.1.7 Recorder: A cable is installed to connect the recorder to the instrument.

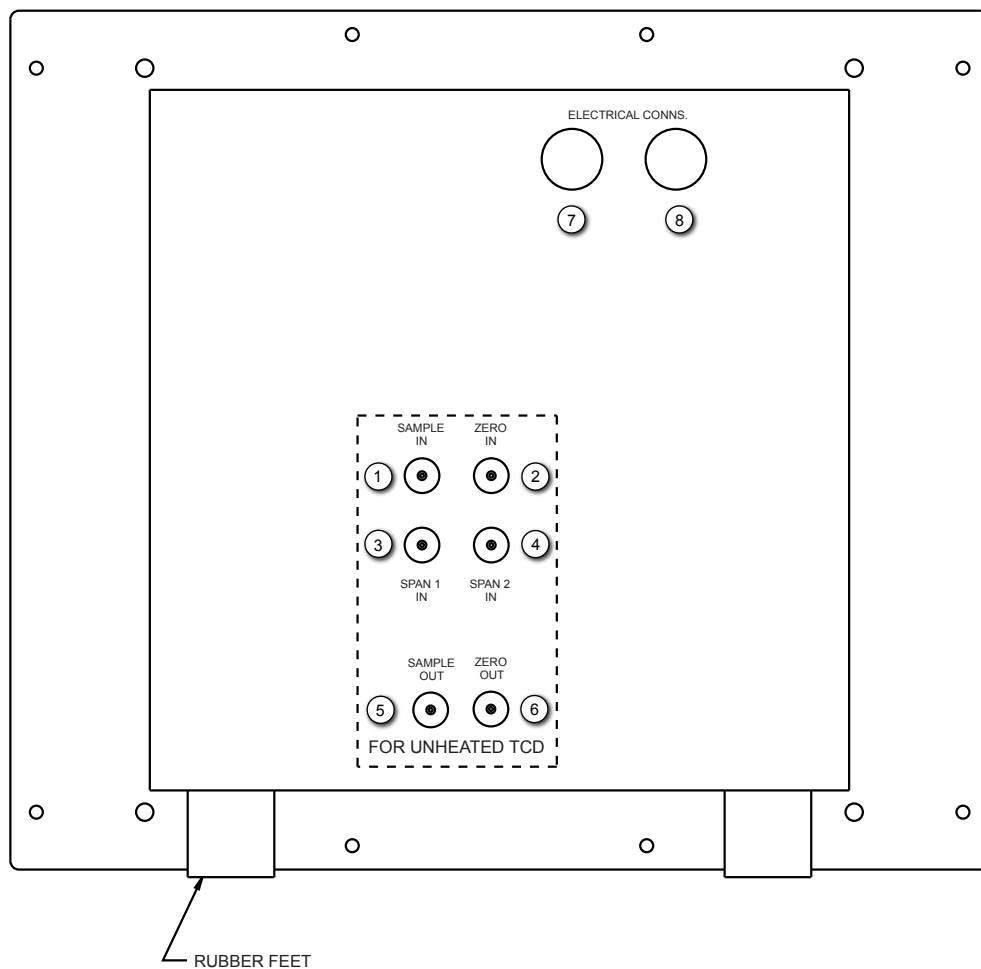

Figure 5-2 Back Panel - Unheated TCD

5.2.2 For HEATED TCD (Figure 5-3)

- 5.2.2.1 Sample In: 1/8" compression fitting. Connect pressure regulated sample gas.
- 5.2.2.2 Zero In: 1/8" compression fitting. Zero gas is the major component of the 2-part mixture to be measured. Connect pressure regulated Zero gas.
- 5.2.2.3 Span 1 In: 1/8" compression fitting. Span 1 is a certified 2-part mixture to set the high end of the calibrated span. The span should be $\pm 20\%$ of the maximum sample concentration. Connect pressure regulated Span 1 gas.
- 5.2.2.4 Span 2 In: 1/8" compression fitting. Use of Span 2 is optional in single range applications unless a second calibration point is desired. In dual range configurations, Span 2 is the principle calibration point for Range 2 while Span 1 is the same calibration point for Range 1. Connect pressure regulated Span 2 gas.

- 5.2.2.5 Sample Out: 1/8" compression fitting. Sample and Span gases exit the instrument through this port. Vent to atmosphere or to a vent manifold at constant atmospheric pressure.
- 5.2.2.6 Zero Out: 1/8" compression fitting. zero gas exits the instrument through this port. Vent to atmosphere or to a vent manifold at constant atmospheric pressure.
- 5.2.2.7 Service Cord: This power cord should be plugged into a grounded receptacle. If a grounded receptacle is not available, use a three/two adapter but make sure that the ground lead is attached to the screw on the receptacle plate.
- 5.2.2.8 Recorder: A cable is installed to connect the recorder to the instrument.

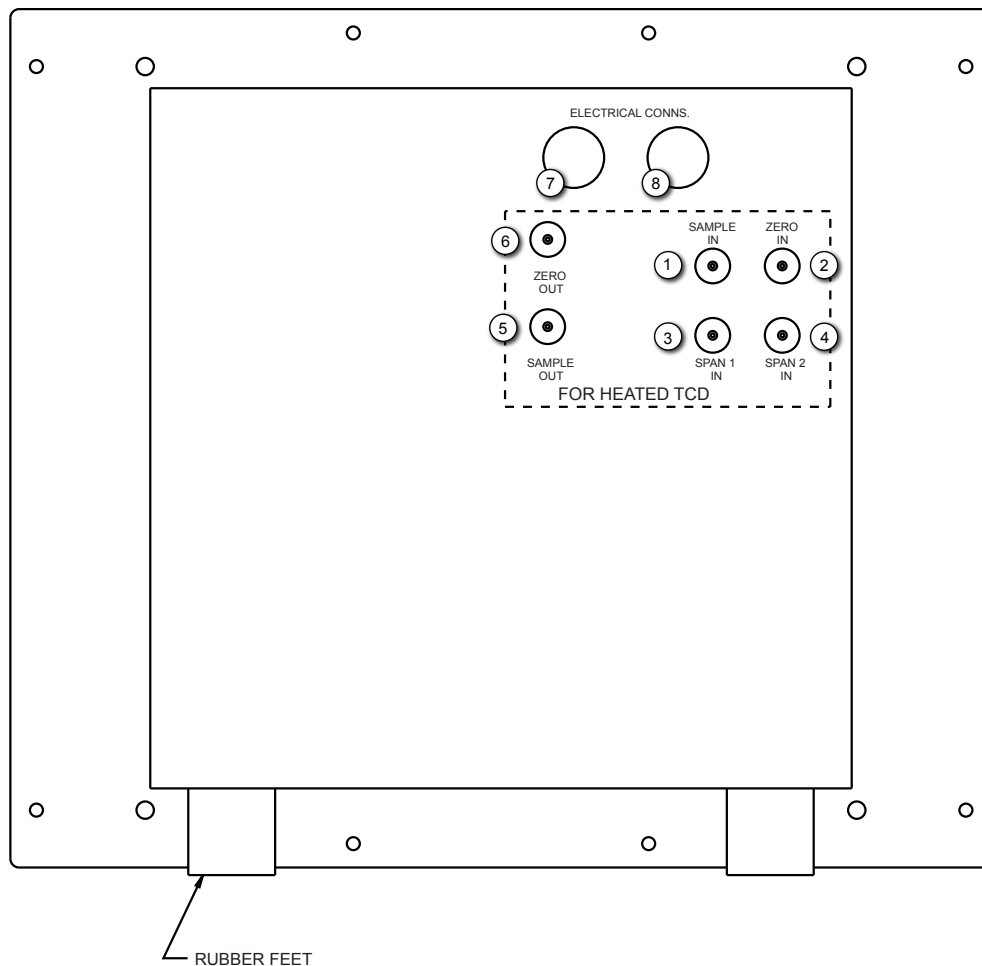

Figure 5-3 Rear panel - Heated TCD

6 Operation

6.1 Gas Flows

6.1.1 Using the GAS SELECTION VALVE to change streams, adjust all gas flows which are indicated on the front panel rotameters:

- for diffusion-type TCD, set to 0.5 scfh
- for semi-diffusion-type TCD (Option 206), set to 50 ccpm

6.2 TCD Bridge Current

6.2.1 After gas flow is established, bridge current can be applied to the detector. Refer to paragraph 5.1.4 and Chart 5-1 to determine maximum bridge current. A safe starting current for all gases is 80 mA for unheated detectors and 60 mA for heated detectors.



GAS MUST BE FLOWING THROUGH THE DETECTOR BEFORE APPLYING BRIDGE CURRENT. APPLYING BRIDGE CURRENT TO THE DETECTOR WITH NO GAS FLOW OXIDIZES THE FILAMENTS. IT IS GOOD PRACTICE TO USE THE LOWEST POSSIBLE DETECTOR CURRENT TO YIELD A GIVEN CALIBRATION.

6.3 Zero Adjust

6.3.1 With flows and current set, turn SPAN POT to "5".

6.3.2 Use ZERO POT to zero the analysis meter.

6.3.3 The unit is now zeroed and ready for calibration.

6.4 Calibrate

6.4.1 Position the GAS SELECTOR VALVE to SPAN 1. Confirm there is proper flow on the rotameter (see 6.1.1, above)

6.4.2 Place the POLARITY SWITCH in a position that causes the readout meter to deflect up-scale. Adjust the SPAN POT until the meter indication agrees with the span gas concentration is indicated on the meter. The polarity of the instrument will be established at the time of calibration.



NOTE

THE ZERO SHOULD BE VERIFIED AFTER INTRODUCING SPAN GAS, AND MAY NEED ADJUSTMENT. IT MAY REQUIRE SWITCHING BACK AND FORTH A FEW TIMES TO ESTABLISH AN ACCURATE CALIBRATION.



IF MORE SENSITIVITY IS REQUIRED, RAISE THE BRIDGE CURRENT IN INCREMENTS OF 10 mA UNTIL SENSITIVITY FOR ANALYSIS IS ACHIEVED.

DO NOT RUN BRIDGE CURRENT HIGHER THAN RECOMMENDED VALUES SET IN THIS MANUAL FOR INDIVIDUAL GASES, Chart 5-1. (Also see page 10 of the General Service Bulletin located on the GOW-MAC website.)

6.5 Check Zero

- 6.5.1 Position the GAS SELECTOR VALVE to the zero position. The meter should go to zero. If meter required re-zeroing, calibration must be checked again.

6.6 Sampling

- 6.6.1 Place the GAS SELECTOR VALVE to the SAMPLE position. Adjust the SAMPLE flowrate (refer to 6.1.1, above). Allow the readout meter to reach equilibrium. The analysis of the sample gas may be directly read from the meter.

Instrument Options

7.1 Temperature Regulated TCD



NOTE

This statement **ONLY** applies to those 20 Series Analyzers that have Option 502 "Temperature Control for Detector"

Your GOW-MAC 20 Series Gas Analyzer contains a Detector Temperature Controller located on the front panel of the instrument. This controller is factory set and **CANNOT** be changed. The buttons located on the controller are inactive.

When the display reads "100" the Gas Analyzer is ready for operation.

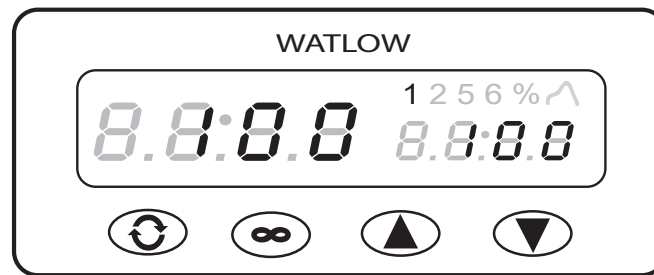

7.2 High/Low Digital Meter Alarm (standard)

- 7.2.1 The meter features up to four (4) setpoint relays controlled by HI/LO setpoint adjustments accessible through the program in the meter. The setpoints on the meter are adjustable over the entire -9999 to +9999 display range. The meter comes with two (2) setpoints (standard); four (4) setpoints (optional).
- 7.2.2 These setpoints, adjustable through the program, can be used for limit alarm functions, ON/OFF control, two-position differential control, three-position control and limit-cycle control.
- 7.2.3 As shipped, both relays are de-energized when the input valve is between the LO and HI setpoints. When the input value falls below the LOW setpoint, the LO relay (SP1) energizes. When the input value rises above the HIGH setpoint, the HI relay (SP2) energizes.

7.2.4 Red "SP1" and "SP2" annunciators on the digital meter light when their respective relays are energized.

7.3 Digital Meter - Programming Summary (standard)

7.3.1 Setpoint Alarm Parameters

To access alarm setpoints,

- a. Press PAR button until SP-1 appears on display.
- b. Use up (⤴) and down (⤵) arrows to change setpoint.
- c. Press PAR button to accept changes.
- d. Repeat steps A - C for SP2.
- e. Repeat steps A - C for SP3 & SP4 (optional).

If further instruction is necessary for instrument set-up and programming, refer to the enclosed panel meter (Model PAX) operating manual supplied by Red Lion (Bulletin No. PAX-W, Drawing No. LP0545, Released 07/24).

Trouble Shooting

- | | |
|---|---|
| 8.1 Instrument has no power indication | Circuit breaker actuated. |
| 8.2 Unable to zero instrument | Detector elements oxidized (replace elements).
Leaks in gas flow system. |
| 8.3 Noise | Gas flow rate not constant.
Detector current too high.
Defective detector elements.
Power Supply not regulating.
Noisy potentiometer. |
| 8.4 Drift Wide ambient temperature change | Detector current too high.
Leaks in gas flow system. |

Replacement Parts

<u>Description</u>	<u>Part No.</u>
Potentiometer, 50K Ω (recorder calibrate, digital meter)	111-131
Potentiometer, 2K Ω (recorder calibrate, analog meter)	111-152
Potentiometer, 1K Ω (zero control)	111-175
Potentiometer, 200 Ω (span)	111-123
Switch (power)	120-166
Switch (power) for heated TCD only	120-173
Switch, toggle (polarity)	120-119
Meter, 2-1/2" (bridge current)	128-107
Counting Dial (for calibration)	127-497
Knob (for zero & current)	127-354
Knob, locking type	127-386
Power cord, 3-conductor shielded	127-407
Power Supply with Signal Amplifier and external Current Pot. (115 V)	123-189-A-2
Power Supply with Signal Amplifier and external Current Pot. (230 V)	123-189-A-2-230
Cordset, 8'	127-131
Recorder Cable	141-354
Rotameter with Valve, Air, 0.2 - 2.0 scfh (for all detectors except Option 206)	180-128
Rotameter, no valve, Air, 0-130 sccm (for Detector Option 206 only)	180-216
5-way brass valve	180-595-1
5-way st.st. valve	180-597-1

Detector (Thermal Conductivity Detector)

Due to the variety of detector and filament options available, please contact GOW-MAC with the serial number of the instrument. The correct detector part will be determined. If the filaments are field-replaceable, the correct replacement filament quad part number will also be determined.

Options

Digital Meter (analysis readout)

Refer to the instrument wiring schematic or contact GOW-MAC with the instrument serial number to determine the correct replacement meter.

Switch, DPDT (dual range)	120-164
Switch, DPST (CSA)	120-245
V/I Converter (4 - 20 mA)	123-178
Heater, for detector (120 V)	124-181
Heater, for detector (230 V)	124-182
Temperature Controller	124-262
Platinum Probe	124-175
Thermocouple	125-112
Receptacle, with inline filter (115/230 V)	129-411-10A

Appendix A: 20 Series Gas Analyzer with Purge Option



NOTE

This instrument purge gauge assembly, Option 600, is designed to meet the instrument pressurization requirements set forth by the NFPA 496 standard for installation in a Class I Division 2 area. It is not suitable for use in Class I Division 1 or other classified areas. The customer or end-user is responsible for the installation meeting all aspects of the NFPA 496 code. The following information is provided only to assist the end user. NFPA 496 or similar code in effect at the installation site should be understood by the end user before operating equipment in a hazardous or classified area. The terms purge, protective, and pressurization are used interchangeably herein when referring to the instrument purge gas.

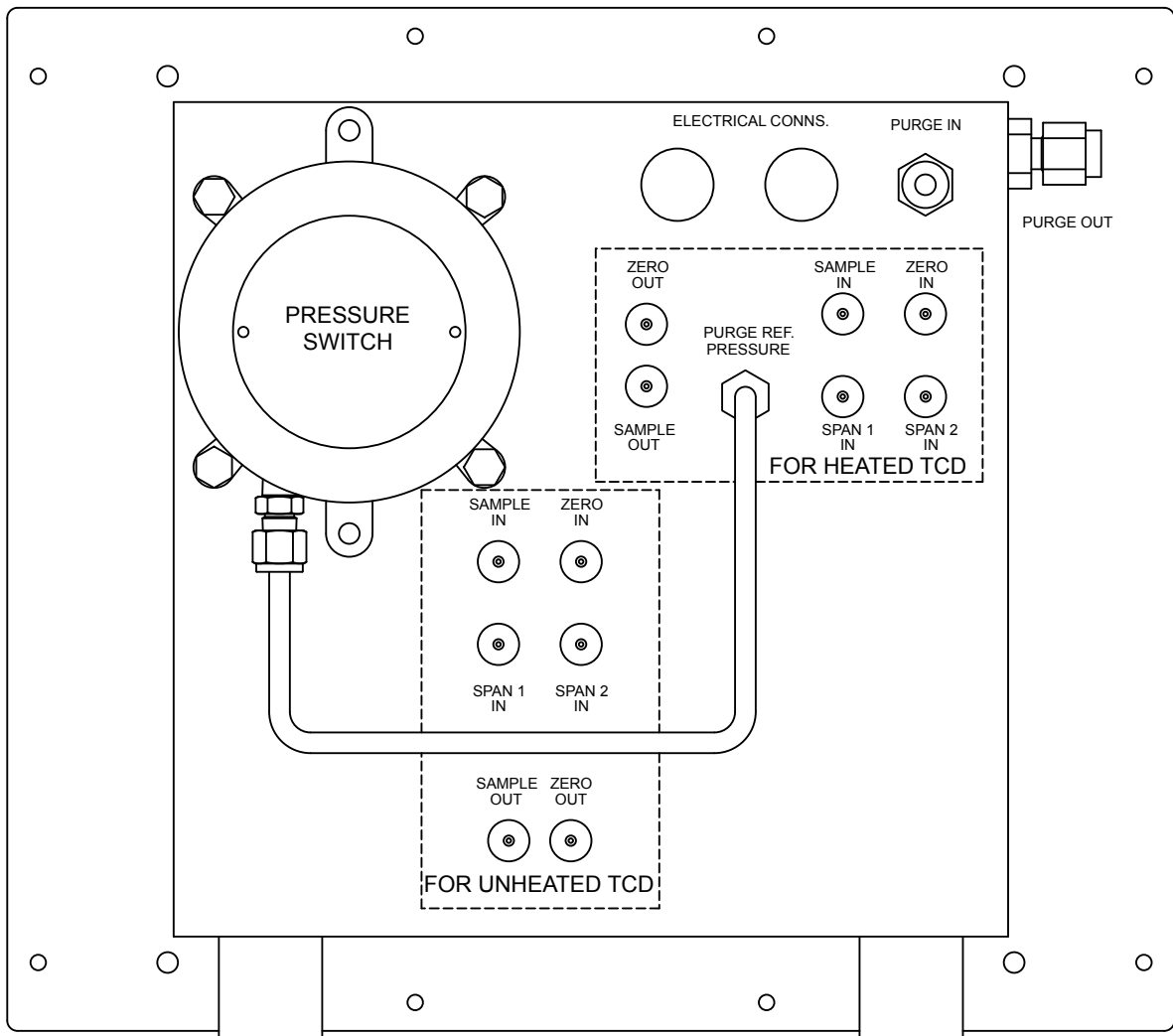

Figure A-1: Back Panel - Purge Option

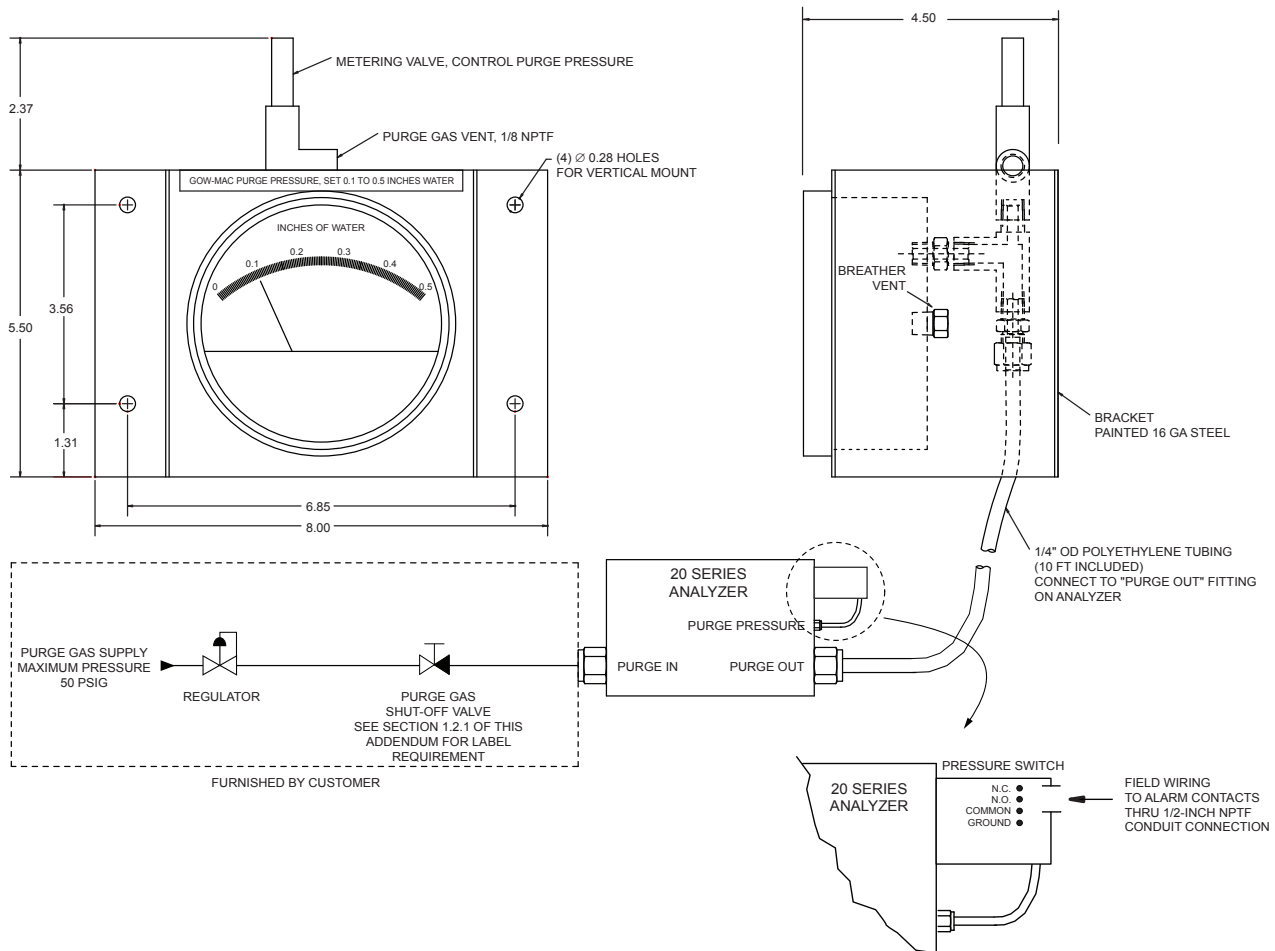

Figure A-2: Installation

A.1.0 Installation (refer to Figures A-1 and A-2))

- 1.1 The purge gas may be compressed air if it has been filtered for moisture, oil, and particles. Unfiltered compressed air may contain contaminants that will damage the instrument electronics. The purge gas supply should include a pressure regulator with 0-60 psi output and a shut-off valve (refer to Figure A-2).
- 1.2 Locate the purge gas IN and OUT fittings on the 20 Series case (refer to Figure A-1). Both purge connections are 1/4-inch compression fittings.
- 1.3 Locate the purge gas supply shut-off valve either immediately adjacent to or remotely from the analyzer.
 - 1.3.1 If immediately adjacent: Need label for purge gas supply valve (**both label and valve are customer-furnished**) if such valve is located immediately adjacent to protected enclosure. The valve label shall read as follows:

WARNING

Protective Gas Supply Valve

This valve must be kept open unless the area is known to be nonflammable or unless all equipment within the protected enclosure is de-energized.

- 1.3.2 If remote: Alarm must be used upon loss of pressure if the shut-off valve is located remotely from the enclosure. Refer to Section 1.5.
- 1.3.3 Indicator may be used if shut-off valve is immediately adjacent to the enclosure and valve is intended for use only during servicing of the enclosure. In this case, there must be marking per 1.2.1. The 0 - 0.5 inches water pressure gauge included in Option 600 meets the indicator requirement.
- 1.4 Connect the purge gas supply to the PURGE IN fitting on the instrument. Connect the enclosed 1/4-inch poly hose between the instrument PURGE OUT fitting and the 1/4-inch tube fitting on the purge gauge assembly, located below the valve. The meter must be oriented vertically for accurate operation. There is a sintered insert behind the meter which serves as dust filter for the atmospheric pressure reference. The sintered area must be kept clean and in still air for accurate gauge performance.
- 1.4 The valve on the purge gauge assembly provides a degree of pressure control. There may be greater control with the purge supply pressure regulator. The valve outlet is 1/8-inch NPT female pipe thread. The purge flow gas exits through this port. The purge gas outflow can be discharged to the Division 2 location because the analyzer does not create ignition-capable particles during normal operation.
- 1.5 A differential pressure switch is installed on the back of the 20 Series cabinet. The switch high pressure port is connected to the cabinet interior via 1/4-inch tubing. The switch uses atmospheric pressure as a reference at the low pressure port. A flame arrestor is installed in both the high and low pressure ports. Electrical connections to the switch are made by removing the cover, which is attached with four (4) 7/16-inch hex screws. Use the correct wire gauge for the alarm circuit current rating (maximum 15 A). Protect the switch from the atmosphere by running the wires to the switch in conduit. The conduit connection on the switch is 1/2-inch NPT female thread. The switch set point is factory set to 0.1 inches water pressure. The set point can be adjusted with a screw located on top of the switch under a protective cover. Turn clockwise to increase the set point and counter-clockwise to decrease the setpoint.

A.2.0 Operation

- 2.1 The protected enclosure shall be constantly maintained at a positive pressure of at least 0.1 inches water above the surrounding atmosphere during operation of the protected equipment. The GOW-MAC 20 Series enclosure requires a minimum supply pressure of less than 5 psig to maintain 0.1 inches water. The purge gas supply pressure should be controllable between 0 to 5 psig to maintain analyzer cabinet pressure in the range between 0 to 0.5 inches water.
- 2.2 Failure to maintain positive pressure within a protected enclosure shall be detected

by an alarm or indicator. Automatic de-energizing of the analyzer is not required in a Class I Div 2 area.

2.3 The enclosure shall **NOT** be opened unless the area is known to be free of flammable materials or unless all devices within have been de-energized.

2.4 Power shall **NOT** be restored after enclosure has been opened **until** the enclosure has been purged for 10 minutes at an enclosed purge pressure of 0.5 inches water.

3.0 Purge Option Specifications

Differential Pressure Switch

Temperature Limit on 20 Series Analyzer	ambient to 120 °F (ambient to 49 °C)
Operating Pressure Range	0.07 to 0.15 inches water
Rated Pressure	45 inches water (0.1 bar)
Maximum Surge Pressure	10 psig
Dead Band	0.05 inches water
Electrical Rating	15 Amps @ 125, 250, 480 VAC, 60 Hz
Wiring Connections	Three (3) #6 screws: common, norm. open, norm. closed, ground
Conduit Connection	1/2-inch NPT female
Housing	Anodized cast aluminum, explosion-proof, drip proof
Diaphragm	silicone on nylon
Breather Vent on Low Pressure Port	304 stainless steel housing, 316 stainless steel, 100 micron sintered element

Differential Pressure Gauge

Temperature Limit	20 °F to 140 °F (-7 °C to 60 °C)
Operating Pressure Range	0 to .50 inches water
Accuracy	+/- 3% of full scale at 70 °F (21 °C)
Breather Vent on Low Pressure Port	304 stainless steel housing, 316 stainless steel, 100 micron sintered element

4.0 Purge Option Replacement Parts

<u>Part Number</u>	<u>Description</u>
120-239-24	Differential Pressure Switch, set 0.07-0.15 inches water
128-269	Differential Pressure Gauge, 0-0.5 inches water
141-163	Bracket for gauge 128-269
163-174	Polyethylene tubing, 1/4-inch OD, 0.062 inch wall
171-392	Breather, 100 micron sintered 316 stainless steel, 1/8-inch NPT male (installed in low pressure ports in pressure gauge and pressure switch)
180-756	Metering valve on pressure gauge
198-213	Label, Warning for opening purged enclosure

Reference: NFPA 496, Standard for Purged and Pressurized Enclosures for Electrical Equipment, 1998 Edition

Health and Safety Declaration for the Return of GOW-MAC Instrument Co. Equipment

In order to protect our employees from exposure to various hazards, the following statements and/or questions **MUST** be answered by you. Fill out this document in its entirety and either fax or e-mail it to GOW-MAC Instrument Co., Attn: Repair Dept, **BEFORE** returning the product.

The instrument/part being returned **will not** be accepted into GOW-MAC's facility until we receive this completed document, along with a **PO or Credit Card**. Once approved for return by our Chemical Safety Officer, a **Return Materials Authorization (RMA) number** and shipping instructions will be issued. *All applicable regulations should be followed when returning instrumentation, and/or parts.*

Customer to Record the Following:

Model # / Part # _____

Serial #: _____

Service Technician spoken to: _____

Today's Date: _____

IF THIS FORM IS NOT APPROVED BY OUR CHEMICAL SAFETY OFFICER, THE INSTRUMENT/PART WILL NOT BE PERMITTED INTO OUR FACILITY FOR SERVICING!

- A) Brief explanation of issue: _____
- B) Briefly list the application(s) for which the instrument/part was used, as well as any and all chemicals, gases, and/or materials analyzed and their concentrations. **(Must be filled in)**: _____
- C) Is there the possibility of internal or external contamination on or in this instrument/part?
 Yes – see below No – proceed to D.

Please check the appropriate box.

- Chemicals or Substances That Are Hazardous to Health
- Blood, Body Fluids, (e.g. Urine, Secretions), Pathological Specimens
- Regulated Medical Wastes
- Infectious Substances or other Bio-Agents (e.g. Protein, Enzymes, Antibodies)
- Radioactive Isotopes used in the area. Detail type (ECD, Isotopic Labels, etc) and Activity in Micro Curies
- Biodegradable Material That Could Become Hazardous
- Other Hazards _____

If any of the above boxes are checked the following statements and/or questions must be answered.

1. Specifically describe where (on or in) the instrument/part there could be any residual contamination (for example: blood spill on the surface). _____
2. Provide details of these hazards. Include names, Material Safety Data Sheets (MSDS), and concentration of contaminants, where possible. _____
3. Describe the method of decontamination used. Attach Procedure. _____

- D) I declare that the above information is true and complete to the best of my knowledge. I acknowledge that any inconsistencies between the condition of the instrument and the statements made on this form will delay the repair process.

Authorized signature _____ Date: _____

Name (Printed) _____ Phone number: _____

Company name: _____ Fax number: _____

Shipping address: _____

City: _____ State/Country: _____ Zip: _____

E-mail address: _____

BEFORE item can be shipped, fax completed form to: (610) 954-0599 or e-mail it to: repairs@gow-mac.com

For GOW-MAC Use Only:	Signed: _____	Date ____/____/____
<input type="checkbox"/> Passed Safety Inspection. OK to proceed to Repair Dept.	Chemical Safety Officer	Comments: () None
<input type="checkbox"/> Failed safety inspection. DO NOT proceed to Repair Dept.	RMA No: _____	() On Back >>>>



REP-005
Health-Safety Declaration Doc – ONLINE
Rev.7 1/28/2022, kj

