

Operating Manual

Series 5200 & 5200P Binary Gas Analyzer

Series 5200: 115 V, 60 Hz

Series 5202: 230 V, 50 Hz

January 2025

Rev. 3

**READ INSTRUCTIONS
BEFORE OPERATING**

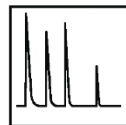

GOW-MAC[®]
INSTRUMENT CO.

277 Brodhead Road, Bethlehem, PA 18017-8600 U.S.A. Tel: (610) 954-9000

SERIES 5200 CONTINUOUS THERMAL CONDUCTIVITY GAS ANALYZER OPERATION AND MAINTENANCE MANUAL

This manual provides operating instructions and maintenance requirements for the Series 5200 Binary Gas Analyzer to permit safe and efficient use of your instrument. It is important that you thoroughly read this manual BEFORE operating your instrument. Failure to do so could result in damaging the instrument and/or yourself. Certain sections of this manual pertain to specific options you may or may not have chosen for your instrument. Please read them carefully and check the enclosed schematics to ensure proper operation. Operate the Series 5200 Binary Gas Analyzer according to the operating procedures stated herein. Any questions concerning the safe and proper use of your instrument should be addressed to:

Mail: GOW-MAC Instrument Co.
277 Brodhead Road
Bethlehem, PA 18017

Tel: (610) 954-9000

Fax: (610) 954-0599

Email: sales@gow-mac.com

Table of Contents

GENERAL PRECAUTIONS FOR HANDLING AND STORING HIGH PRESSURE GAS CYLINDERS.....	7
SECTION 1: SAFETY.....	9
SECTION 2: PRINCIPLE OF OPERATION.....	11
SECTION 3: SPECIFICATIONS.....	13
SECTION 4: INSTALLATION	15
SECTION 5: COMMUNICATIONS.....	23
QUICK START GUIDE	27
SECTION 6: OPERATING CONTROLS.....	29
SECTION 7: INSTRUMENT OPERATION	37
SECTION 8: TROUBLESHOOTING	41
SECTION 9: REPLACEMENT PARTS	43
Appendices	45
1. Error Message Glossary	
2. Default Gas Flows and Currents	
3. Drawings and Schematics	
WARRANTY	47
HEALTH & SAFETY DECLARATION FOR INSTRUMENT RETURN	49

GENERAL PRECAUTIONS FOR HANDLING AND STORING HIGH PRESSURE GAS CYLINDERS

Compressed gases have properties that can cause serious accidents, injuries, and even death if proper precautions and safety practices are not followed. Therefore, during handling and use of these gases, be certain to use applicable safety precautions described by your local compressed gas supplier, the Compressed Gas Association, and/or O. S. H. A. regulations.

1. Read the label on all cylinders **BEFORE** using to identify the cylinder contents. If the label is illegible, return the cylinder to the supplier. **DO NOT ASSUME THE CONTENTS.**
2. Secure cylinders in storage and in use to an immovable structure to prevent accidental falling or movement. Read the relevant safety codes.
3. Store or move cylinders **ONLY** in the vertical position. **DO NOT** move or transport cylinders with regulators attached.
4. Store cylinders in a well-ventilated area away from heat or ignition sources.
5. When installing tubing, provide **ONLY** approved, adequate pressure reducing regulators and pressure relief devices to prevent over-pressurizing of tubing and equipment.
6. Never drop cylinders or permit them to strike each other violently.
7. Cylinders may be stored in the open but, in such cases, should be protected against extremes of weather and from damp ground (to prevent rusting). In areas where extreme temperatures are prevalent, store cylinders in the shade.
8. The valve protection cap should be left on each cylinder until the cylinder has been secured against a wall or bench, or placed in a cylinder stand and is ready for use.
9. Avoid dragging, rolling, or sliding cylinders even for a short distance. Move cylinders by using a suitable hand truck.
10. Never tamper with safety devices in valves or cylinders.
11. Do not store full and empty cylinders together. Serious suck-back can occur when an empty cylinder is attached to a pressurized system.
12. No part of a cylinder should be subjected to a temperature higher than 52 °C

(125 °F). Do not permit flame to come in contact with any part of a compressed gas cylinder.

Section 1

Safety

This section contains information to promote safety in the operation and maintenance of this equipment. It is not intended to supersede, replicate, or replace any safety documentation or procedures provided from or established by official safety sources.

All persons involved with the operation of this equipment including plant engineering, operations, and management must understand the potential hazards involved, and know and observe all required safety precautions.

Your safety and the safety of equipment, nearby facilities, and personnel require a proper safety attitude and emphasis on safe work procedures. This is the essence of any good safety program. If at any time you identify safety deficiencies, immediately correct them, and bring them to the attention of management.

Before an accident can be prevented, it must be anticipated. Use pre-job discussions with your co-workers and supervisors to identify hazards and the means to avoid them. At your facility, various gases may exist in liquid and/or gaseous states. Familiarize yourself with the hazards associated with each gas found at your facility.

Read and understand the Safety Data Sheets (SDS) for the materials used with this equipment. All personnel who work in the vicinity of this equipment should read, understand, and follow all safety information contained in the SDS, in addition to following all government and facility safety regulations.

GENERAL SAFETY WARNINGS

1. The Series 5200 Binary Gas Analyzer should be installed, operated, and maintained in strict accordance with its labels, cautions, warnings, instructions, and within the limitations stated.
2. The Binary Gas Analyzer housing must be in a non-hazardous area.
3. Use genuine GOW-MAC replacement parts when performing any maintenance procedures provided in this manual. Failure to do so may seriously impair instrument performance. Repair or alteration of the Series 5200 beyond the scope of these instructions or by anyone other than GOW-MAC or a GOW-MAC Representative could cause the product to fail to perform as designed, and persons who rely on this product for their safety could sustain severe bodily injury or death.
4. DISCONNECT the instrument from **ALL** power sources **BEFORE** removing chassis from instrument housing and exposing potentially dangerous voltages.
5. **DO NOT** overload the AC outlet with other electrical equipment.
6. Adhere to the color-coding descriptions when hooking up electrical connections.
7. Repair or replace faulty or frayed wiring.
8. Ensure that the actual line voltage is the value for which the instrument was designed. Ensure that the power cord is plugged into the correct voltage source.
9. Perform periodic leak checks on all fitting areas.
10. **DO NOT** allow flammable and/or toxic waste to accumulate.
11. Keep combustibles away from gas cylinders and eliminate ignition sources.
12. Maintain adequate ventilation around the Binary Gas Analyzer.
13. Dispose of waste properly.

Section 2

Principle of Operation

A. Detectors

1. Thermal Conductivity Detector (TCD)

The thermal conductivity detector (TCD) consists of a relatively large mass of metal to provide a stable heat sink. Stainless steel is generally used because of its compatibility with most sample gases and its high thermal conductivity. Gas channels and recessed cavities are drilled in the detector for sensors which are either hot wire filaments or thermistors. Standard filaments used in the Series 5200 Gas Analyzer are fabricated from either rhenium-tungsten (WX) or tungsten (W2). Other materials are available upon request. The filaments are connected to form a Wheatstone bridge that is powered by a high-quality constant current source. The bridge output is electrically zeroed. An imbalance in the bridge occurs when gas with different thermal conductivity than the reference gas is flowing. The imbalance magnitude is proportional to the thermal conductivity difference.

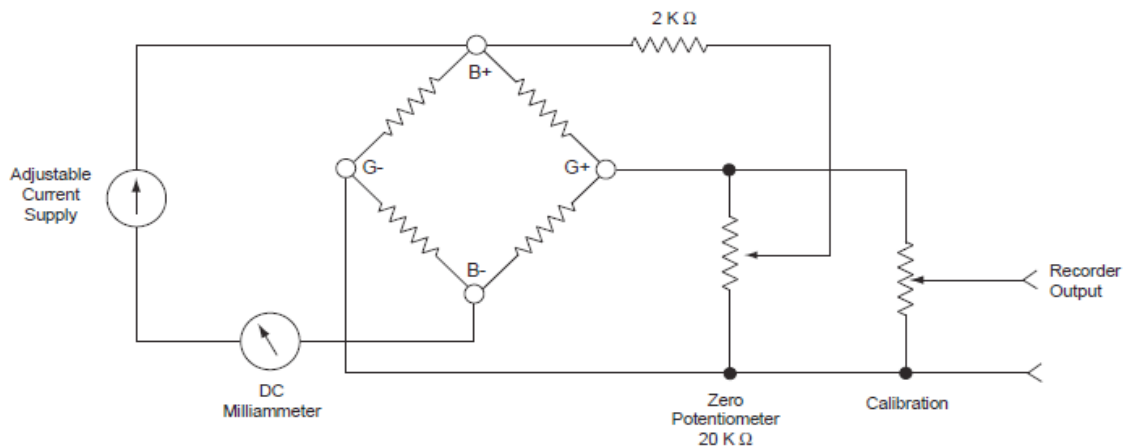

Figure 1. Thermal conductivity cell basic circuit

The standard TCD type in the Series 5200 is a diffusion design which is relatively insensitive to gas flow rate and has a response time of less than 15 seconds at about 200 ccpm.

The 5200 features a fail-safe in which certain conditions including loss of gas flow trigger shut off of detector current to prevent filament damage. If flow or TCD temperature strays a certain amount away from setpoints, current will be shut off and automatically reset when the setpoint(s) is again satisfied.

B. Flow System

The Series 5200 standard gas flow configuration is dual pass indicating that there are two gases flowing continuously: reference and sample. These gases are controlled using internal thermal mass flow controllers. The flow for each gas can be set on the touchscreen.

C. Electronics

A 7-inch touchscreen is used for all settings and readouts (signal, ppm, %). Amplification of the signal increases the sensitivity of the instrument and allows the operator to run the detector at a lower filament current. Detector current and sensitivity are directly proportional. However, filament life is prolonged by using the lowest current that works for the application (gas pair and relative concentrations). Detector current is provided by a solid state constant current power supply. The TCD is temperature-controlled in an insulated enclosure. Temperature is set and monitored on the screen.

Section 3

Specifications

Detector	Diffusion Type -Thermal Conductivity (TCD)
Ranges	User selectable nominal ranges. Upper limits are function of signal. Ranges 1-4 limits are subject to change with varying current for different gas pairs.
Detector Temperature	100 °C (default) User programmable in range 0-100 °C
Operating Temperature	15°C – 35°C (59°F – 95°F) ambient
Sensitivity	30 ppm N ₂ in He Values for other gas pairs are function of thermal conductivity differences
Sample Flow Rate (unless otherwise stated)	50 – 500 cm ³ /min.
Response Time (standard diffusion TCD)	Less than 15 sec.
Repeatability	+/- 0.5% of span
Communications	Analog: 4-20 mA, 0-5 VDC Digital: RS-232 serial, USB data logging
Relays	Programmable relays for two (2) high/low concentration alarms (2) 1A alarm relays and (1) ready relay
User Interface	7-inch graphical resistive LCD touchscreen
Power Requirement	5200: 120 W at 115 VAC, 60 Hz 5202: 120 W at 230 VAC, 50 Hz
Gas Process Connections	1/8-inch compression fitting, stainless steel
Dimensions, Model 5200 non-purgeable case	7 in (17.8 cm) H x 19 in (48.3 cm) W x 21 in (53.4 cm) D Front panel height 4U fits 19-inch-wide EIA standard rack
Weight	5200 or 5202: 28 lbs (13 kg)

Section 4

Installation

GOW-MAC Installation and Training Service

GOW-MAC provides installation and training (in person and remote) services.

Please contact GOW-MAC sales at (610) 954-9000 or email sales@gow-mac.com

Unpacking and Inspection

1. When unpacking the instrument, check it carefully for evidence of shipping damage or rough handling. Check to ensure that all components ordered have either been supplied or backordered. **Report any damage or discrepancies *immediately* to GOW-MAC Instrument Company.**
2. Remove all plastic and/or paper shipping caps and restraints before operating.

Site Prep and Installation

1. Electrical Connections

Connect the supplied AC power cord between the receptacle on the back panel and voltage specified for the model.

Series 5200 - 120 Watts at 115 V, 60 Hz

Series 5202 - 120 Watts at 230 V, 50 Hz

A grounded electric outlet should be in the installation area within reach of the included power cord. The instrument is shipped with a power cord plug that is specific for the destination country noted on the equipment order.

An extension cord should NOT be used for the 5200 because extension cords may not be rated for instrument power. For best results, use a dedicated service receptacle to prevent disruption from transient loads. The electric power must be steady to provide optimum instrument stability. If necessary, install a stabilizing power transformer between the receptacle and the 5200. In addition, a surge/noise suppressor with lightning arrestor should be installed between the receptacle and the 5200. The minimum capacity/ratings for a surge/noise suppressor are 2 A at 115 V and 1 A at 230 V.

Grounding: A proper earth ground is required for instrument operation. Any interruption of the grounding conductor or disconnection of the power cord could cause a shock that could result in personal injury. The metal instrument panels, and cabinet are grounded through the three-conductor power cord that, when plugged into a properly grounded receptacle, grounds the instrument and minimizes shock hazard. A properly grounded receptacle is one that is connected to suitable earth ground. Be sure to verify proper receptacle grounding.

2. Environmental

The Series 5200 Binary Gas Analyzer can be installed on a table or in a 19-inch rack. Use a shelf or similar support for installation in a rack due to the instrument's weight and depth. Allow about 12 inches of clear space from the instrument back panel for gas tubing and electrical connections.

Install the analyzer in a location that is secure, vibration free, and has a stable ambient temperature. For optimum instrument stability, the ambient operating air temperature should be maintained as steady as possible within the range 15 to 35 °C (59 to 95 °F). Ambient temperature change does cause drift of the calibration.

There must be full access and easy viewing of the front panel of the analyzer. In addition, provisions should be made for access to the rear panel (gas, electrical and comm interfaces). Infrequent access for maintenance requires removal of the instrument top cover.

The height and width of the front panel are designed to fit into an EIA standard 19-inch rack. The 7-inch touchscreen is the display and user interface. The only instrument power switch is on the back panel.

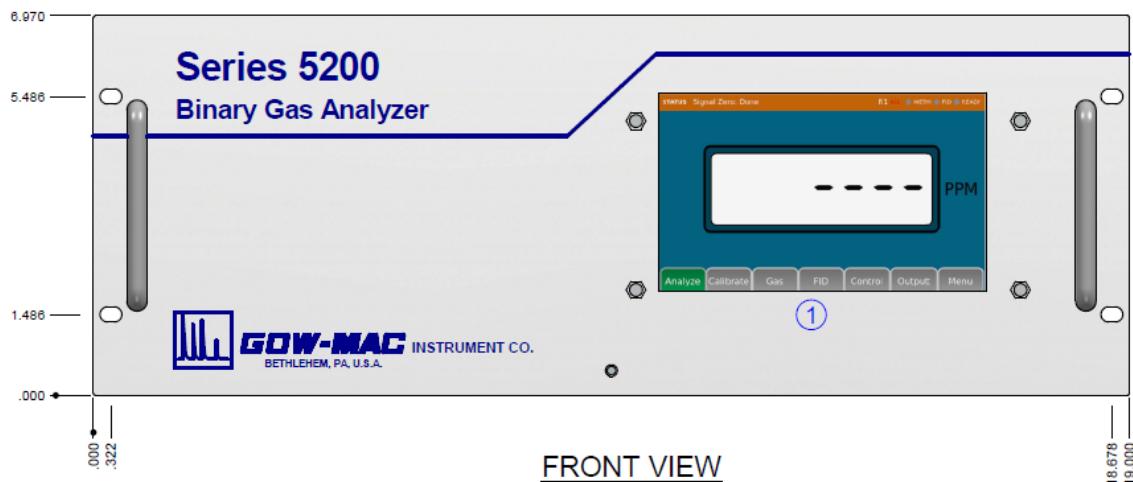

Model 5200 Binary Gas Analyzer front panel, dimensions in inches

3. Gas Connections

Gas connections are on the back panel. All are 1/8" diameter stainless steel compression fittings. Gas parameters for the Series 5200 Binary Gas analyzer are specified in the following table.

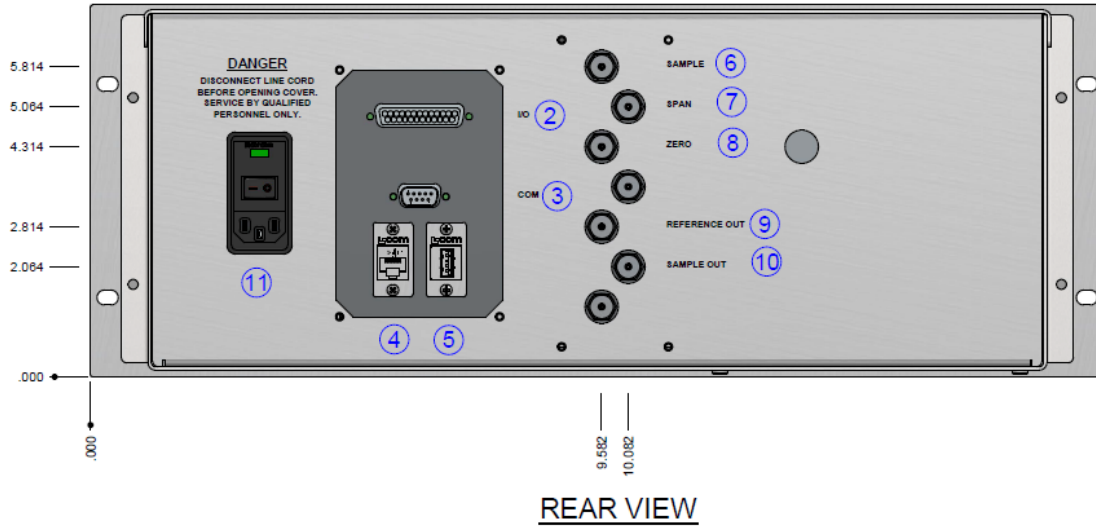

Model 5200 Binary Gas Analyzer back panel and connections, dimensions in inches

NOTES

1. TOUCH SCREEN DISPLAY
2. 25-PIN SERIAL CONNECTION
3. 9-PIN SERIAL CONNECTION
4. ETHERNET CONNECTION
5. USB CONNECTION
6. SAMPLE IN (1/8" COMPRESSION)
7. SPAN (1/8" COMPRESSION)
8. ZERO (1/8" COMPRESSION)
9. REFERENCE OUT (1/8" COMPRESSION)
10. SAMPLE OUT (1/8" COMPRESSION)
11. POWER

DIMENSIONS

7"H x 19"W x 24"D

Gas Selection and Purity

Service	Gas Type	Gas Grade or Quality	Supply Pressure (psig)	Flow Rate (ccpm)
Sample	Various	Non-condensing	10-100	10-500 ccpm
Zero/Reference	Match the sample gas	99.999% pure or any gas with known purity	10-100	10-500 ccpm
Span	Match the sample gas	% value of purity/impurity must exceed that of the sample gas.	10-100	10-500 ccpm

Allow adequate space for the safe and compliant installation of gas cylinders where used.

FOLLOW THE “GENERAL SAFETY WARNINGS” AND “GENERAL PRECAUTIONS FOR HANDLING AND STORING HIGH PRESSURE GAS CYLINDERS” LOCATED AT THE FRONT OF THIS MANUAL. CONTACT YOUR LOCAL GAS SUPPLIER TO ENSURE PROPER HANDLING OF CYLINDERS.

4. Gas Control Components

Connect gases to the 5200 using instrument-grade tubing with no residual contamination. This is essential for analyzing lower levels of impurity. Stainless steel 1/8-inch compression tube fittings with front and rear ferrules are supplied with the instrument for gas tubing connections.

Cylinder Regulators

Where possible, install the 5200 gas supply system with two-stage pressure regulators with metal diaphragm seals made for high purity service. Should sample supply pressure vary due to process conditions, the 5200 internal sample flow controller compensates.

Gas Flow Measurement

All flows are read out directly in cubic centimeters per minute (ccpm) units on the TCD screen.

Leak Testing

After all gas connections have been made and tightened, test each connection for leaks. Leaks in the system will cause baseline drift and noise and may reduce sensitivity. This instrument has been completely leak-tested and checked out prior to shipping. It is possible, but unlikely, that internal leaks have developed during shipment. The most likely source of leaks will be where subsequent connections or reconnections are made by the user.

DO NOT USE soap or other organic substances to check for leaks. If there are leaks, the soap and/or organic substances will be aspirated into the leak and contaminate the system. The easiest way to locate leaks is with the GOW-MAC model 21-080 Mini Gas Leak Detector if the tubing can be pressurized with helium.

5. Instrument Communication Connection Descriptions, 5200 Model only

- a. 25-pin user I/O connection. D-SUB female receptacle with 25 positions described in the following table.

POS.#	POSITION NAME	SPECIFICATION
1	READY (NC)	Contact 30 VDC @ 300 mA
2	ALARM 1 (NO)	Contact 30 VDC @ 300 mA
3	ALARM 1 (COM)	Contact 30 VDC @ 300 mA
4	ALARM 2 (NC)	Contact 30 VDC @ 300 mA
5	NOT USED	
6	NOT USED	
7	NOT USED	
8	NOT USED	
9	NOT USED	
10	REMOTE CALIBRATION INPUT -	Apply 0V (TTL ground)
11	Signal 4-20 mA (LO)	Output protection 240V RMS, 1000-ohm maximum load
12	Signal 0-5V (LO)	5V compliance, 10K ohm minimum load
13	NOT USED	
14	READY (NO)	Contact 30 VDC @ 300 mA
15	READY (COM)	Contact 30 VDC @ 300 mA
16	ALARM 1 (NC)	Contact 30 VDC @ 300 mA
17	ALARM 2 (NO)	Contact 30 VDC @ 300 mA
18	ALARM 2 (COM)	Contact 30 VDC @ 300 mA
19	NOT USED	
20	NOT USED	
21	NOT USED	
22	NOT USED	
23	REMOTE CALIBRATION INPUT +	Apply 5V TTL pulse (active low)
24	Signal 4-20 mA (HI)	Output protection 240V RMS, 1000-ohm maximum load
25	Signal 0-5V (HI)	5V compliance, 10K ohm minimum load

- b. 9-pin serial connection. D-SUB male receptacle with 9 positions described in the following table.

POS. #	POSITION NAME
1	NOT USED
2	RS-232 RECEIVE DATA
3	RS-232 TRANSMIT DATA
4	NOT USED
5	RS-232 GROUND SIGNAL
6	NOT USED
7	NOT USED
8	NOT USED
9	NOT USED

6. Instrument Communication Connection Descriptions, 5200P Model only

- a. 25-pin user I/O connection. D-SUB female receptacle with 25 positions described in the following table.

POS.#	POSITION NAME	SPECIFICATION
1	READY (NC)	Contact 30 VDC @ 300 mA
2	ALARM 1 (NO)	Contact 30 VDC @ 300 mA
3	ALARM 1 (COM)	Contact 30 VDC @ 300 mA
4	ALARM 2 (NC)	Contact 30 VDC @ 300 mA
5	NOT USED	
6	NOT USED	
7	NOT USED	
8	NOT USED	
9	NOT USED	
10	REMOTE CALIBRATION INPUT -	Apply 0V (TTL ground)
11	Signal 4-20 mA (LO)	Output protection 240V RMS, 1000-ohm maximum load
12	Signal 0-5V (LO)	5V compliance, 10K ohm minimum load
13	NOT USED	
14	READY (NO)	Contact 30 VDC @ 300 mA
15	READY (COM)	Contact 30 VDC @ 300 mA
16	ALARM 1 (NC)	Contact 30 VDC @ 300 mA
17	ALARM 2 (NO)	Contact 30 VDC @ 300 mA
18	ALARM 2 (COM)	Contact 30 VDC @ 300 mA
19	RECEIVE DATA	RS-232
20	TRANSMIT DATA	RS-232
21	GROUND	RS-232
22	NOT USED	
23	REMOTE CALIBRATION INPUT +	Apply 5V TTL pulse (active low)
24	Signal 4-20 mA (HI)	Output protection 240V RMS, 1000-ohm maximum load
25	Signal 0-5V (HI)	5V compliance, 10K ohm minimum load

Section 5

Communications

1. USB Connection

The USB port can be used for data logging storage and future GOW-MAC software updates. A thumb drive or external hard drive can be connected here to save the data log text files. It is important to keep track of how much space is used when collecting data. Once the storage is full, the data log will STOP collecting data. A red “USB” light will appear in status bar when a USB is mounted.

2. Serial Data Output

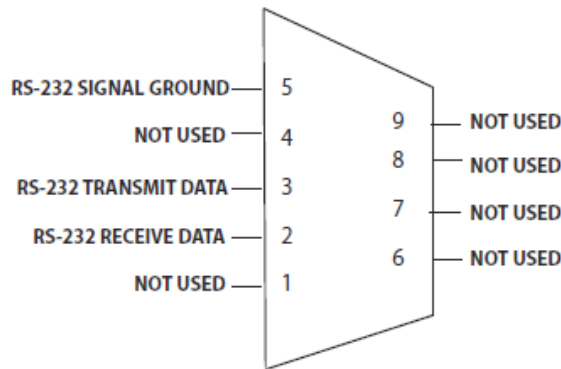

DB9M Pin connections

Communication Settings:

Baud Rate: 9600

Number of data bits: 8

Parity: None

Number of stop butts: 1

Data Format: (5 data fields, space delimited)

- 1 Date
- 2 Time (24hr)
- 3 ppm (display reading only no unit)
- 4 Alarm1_state
- 5 Alarm2_state

Example set @ 10min Interval

```
*****  
7/01/21 11:10:30 103.018 A1_High A2_Low  
7/01/21 11:20:30 105.374 A1_High A2_High  
*****
```

Ethernet Connection Factory use only.

3. Comms In/Out

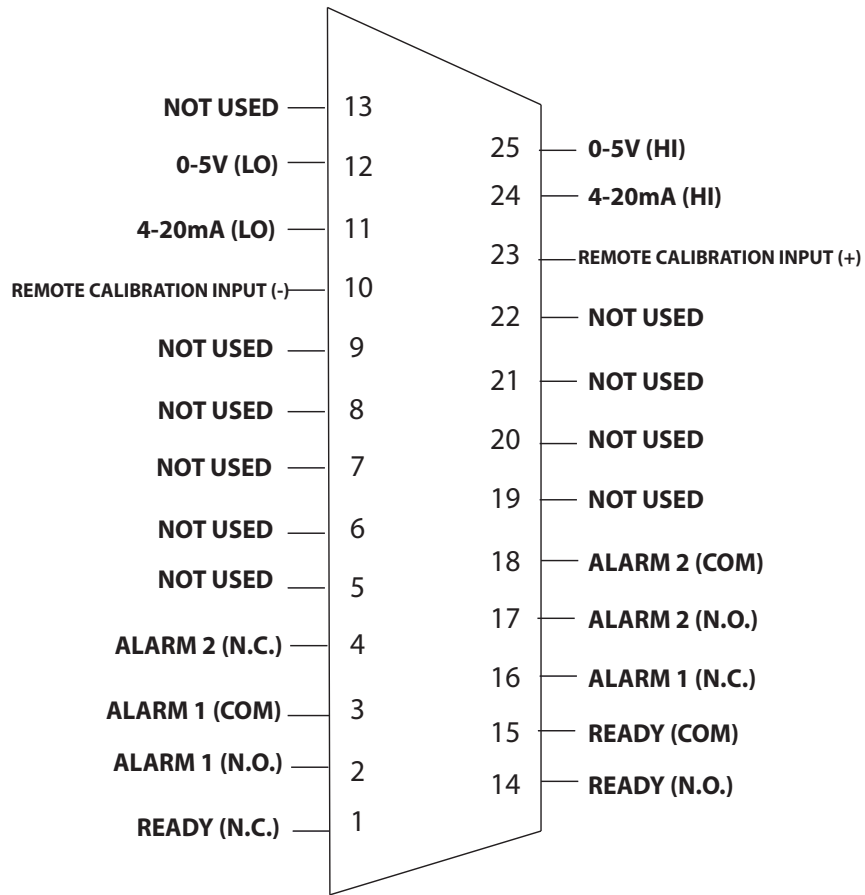

DB25 I/O Connector

a. Analog Outputs

Description: For connection to external data system

- i. 4-20 mA analog output

Rating: output protection 240V RMS, 1000 Ohm maximum load

Connections:

Pin 11 (4-20mA) Lo

Pin 24 (4-20mA) Hi

- ii. 0-5 Volt analog output

Rating. Analog Signal Output: 5V compliance w/ 10K Ohm minimum load

Connections:

Pin 12 (0-5V) Lo-(ground)

Pin 25 (0-5V) Hi

b. Status Relay Outputs

Description: For monitoring system status

Ratings: 30 VDC @ 300 mA

- i. High/Low alarms

Connections:

Pin 2 Alarm 1 N.O.

Pin 16 Alarm 1 N.C.

Pin 3 Alarm 1 Common

Connections:

Pin 4 Alarm 2 N.C.

Pin 17 Alarm 2 N.O.

Pin 18 Alarm 2 Common

- ii. Ready Status Relay – Ready is indicated when calibrated and sample gas is flowing

Description: Instrument operational status indicator

Operation: Normally Open contact

Normally Open Relay contact will be closed when the 5200 system is in ready state

Connections:

Pin 1 Ready N.C.

Pin 14 Ready N.O.

Pin 15 Ready Common

Quick Start Guide

1. Connect zero/reference, span/calibration and sample gases to back panel. The allowable range for gas pressures is 10 to 100 psig. If installing the 5200P (purgeable housing), one additional connection needed is purge gas (see addendum).
2. Turn on the instrument using the switch on the back panel.
3. On the gas tab, select your reference (zero) gas on the right-hand side, and your sample gas on the left-hand side
4. Go to the TCD tab on the bottom of the screen to set detector temperature and flows. The recommended temperature setting is 80-100°C. Set gas flows to 10-25 ccpm while detector is heating up to ensure no damage to filaments. Allow the detector to reach a steady state at the set point.
5. It is essential for there to be sufficient gas flow before turning on TCD current. The recommended flow is 200 ccpm and the reference and sample gas flowrates should match.
6. Set your detector current by pressing the white box in the top right of the TCD tab. Please refer to GOW-MAC's General Service Bulletin when choosing the recommended current. The rule of thumb is to operate at as low a current that provides adequate signal for the analysis.
7. Press the current on/off button to the left of the white box. The button will turn green, and you will see a slow increase of current. Current must reach its set point and stabilize before running the calibration cycles. Allow the instrument 4 – 5 hours to completely stabilize after the current is turned on.
8. Choose your range on the Control tab. Since every gas mix generates a different signal, there are no general guidelines for ranges. The best way to pick a range is to select your span gas and observe the output signal. Pick the lowest range you can go to without seeing the word 'over.' If you are getting a negative signal, press the "Polarity" button to the right of the signal box which will make the signal go positive.
9. Navigate to the calibrate tab to start the calibration process. Calibrate your zero (reference) gas first by entering the total amount of impurities (ppm or %) present in the zero box. If this value is unknown, just enter zero. Then, touch the zero button to start the zeroing process which will take 5 minutes. The button will go back to gray when complete.
10. Calibrate the span next by entering the total amount of impurities (ppm or %) into the Span box and then touch the span button. This process will take 5 minutes and the button will turn gray when complete.
11. Once the zero and span calibrations are completed, go to the Control screen and touch the sample button to open the sample gas valve and start analysis. The instrument will appear as "ready," and the ppm or % value will appear in the Analyze screen and on the status bar when in other screens. To view % impurity or purity, navigate to the TCD screen and select desired display units on the right-hand side. The Analyze screen displays measured ppm or % for whichever gas is selected on the Control screen.

Section 6

Operating Controls

User Interface Screens

The Series 5200 uses a touchscreen for user interface controls. Tabs along the bottom are to navigate between screens.

NOTE ABOUT UNITS USED ON THE SCREENS – When not labeled on the screen, default units are:

Gas Flow = ccpm

Temperature = °C

Signal (on the Control screen) = volts

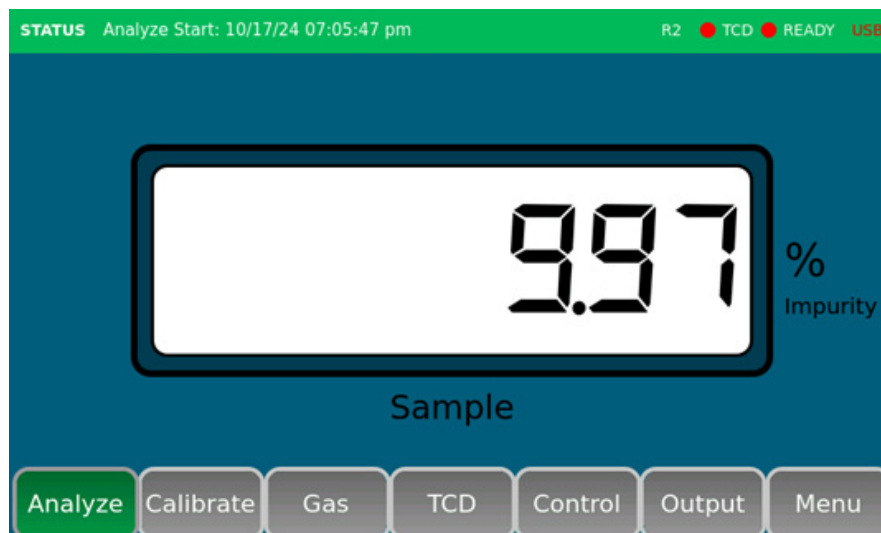

1. Analyze Screen features

Displays concentration in parts per million (ppm), percentage impurity or percentage purity of the detector output. Display units can be selected on the TCD screen. The number of decimal places depends on the selected range. See Control screen description for explanation of ranges.

Status Bar feature. A communication field across the top of the screen indicates instrument status and message.

- The current state of the instrument is based on status bar color.
 - Orange: TCD is off, and instrument is not analyzing. Possible errors.
 - Blue: TCD current is on, setpoints are met, device is uncalibrated.
 - Green: All TCD conditions met, and device has successfully been calibrated
- Range setting indicated by R(1-3).
- TCD indicator lights red when current is on and at setpoint.

- READY indicator lights red when the instrument is ready for analysis, meeting the following conditions:
 - actual temperatures match setpoints
 - sample gas is selected
 - all flows match setpoints
 - successful Zero and Span have been done
- USB indicator light. The “USB” turns red when a properly formatted USB is mounted and recognized.



- Error messages appear to describe a fault. Touch the status bar to expand to a list of the most recent status and error messages. Press “X” to collapse the list.

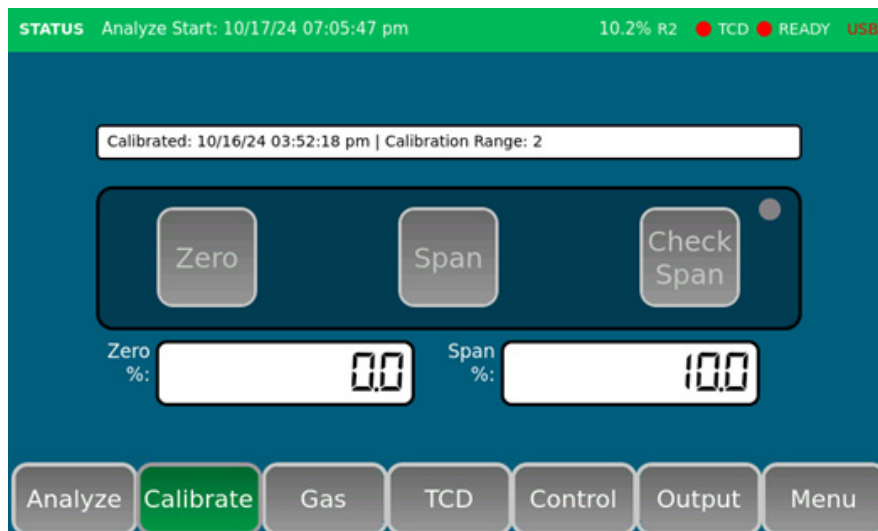

2. Calibrate Screen features

- Date, time, and range of current calibration.
- During calibration, a “Stabilization Timer” will appear in the calibration message box and count down the remaining seconds.

- Buttons to manually start zero, span, and span check cycles.
 - Zero: Switches to zero (reference) gas to determine the actual signal offset for the zero gas provided. The process takes two minutes, and the software will assign a “zero” value to that specific detector signal.
 - Span: Switches to span gas to determine the actual detector signal for the calibration gas provided. The process takes two minutes, and the software will assign a “span” value to that specific detector signal.
 - Span Check: Compares the signal of the current span gas to the last saved span value. If the two values are within 2% of each other, the check span light will turn green, and the span is considered good. If the light turns red, re-calibration is needed.
- Below the zero and span buttons are fields to enter the total amount of impurities in the reference and sample gas. These values must be entered in the units that are selected on the TCD page (ppm or % impurity).
- The calibration process of zero and span can be remotely triggered via the DB25 I/O connector on the back panel. Please refer to Section 5 – Communications.

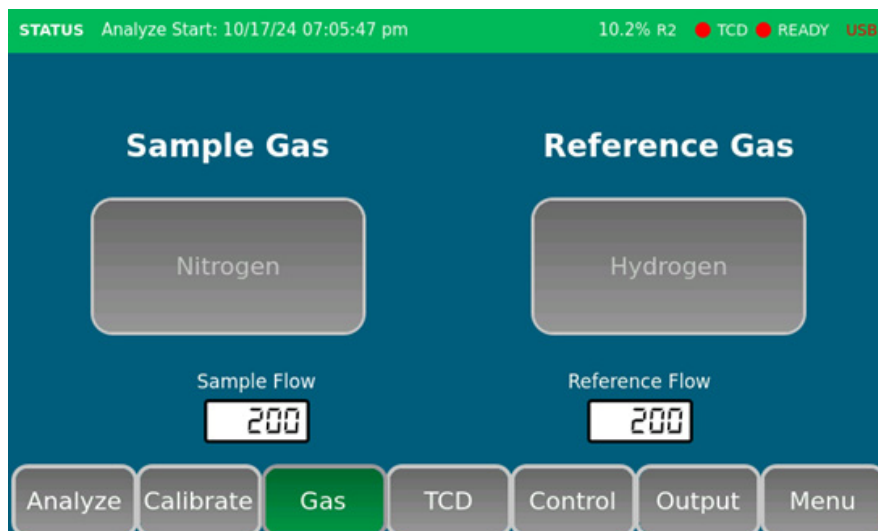

3. Gas Screen features

- Buttons to select sample and reference gas.
 - Sample gas is the gas with impurities. Please select the balance gas of the sample. (i.e. if you are analyzing 5% He in N₂, select N₂ as your sample gas.)
 - Reference gas is also referred to as the “Zero” gas.
- Fields that show the stored flow settings for each gas mixture. These will appear as “0” until the flow has been saved.

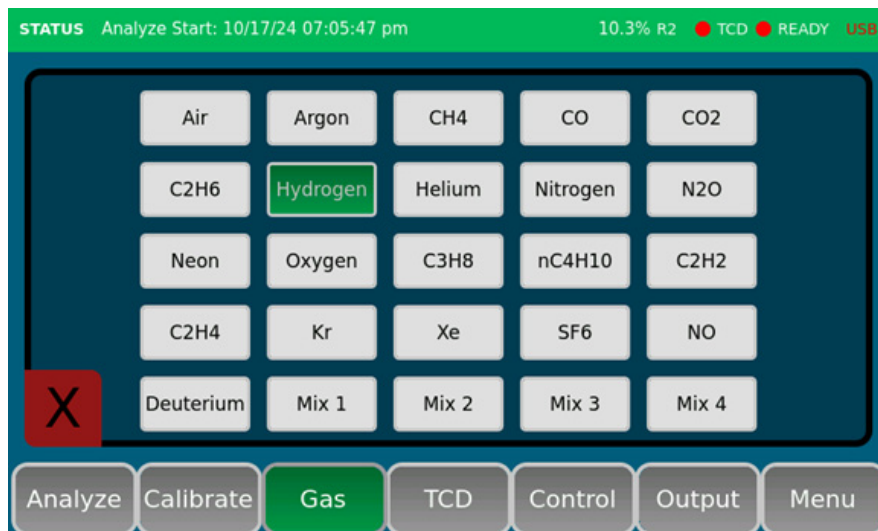

- Exit the gas selection by touching the “X” button.

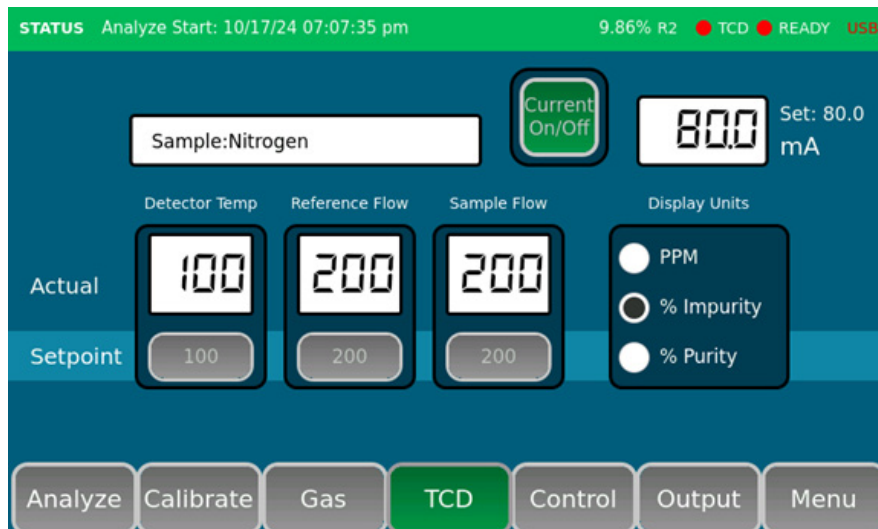

4. TCD Screen features

- Field shows the selected sample and reference gas combinations.
- User-programable TCD current field with On/Off button.
- Current (mA) field shows actual value of current when turned on.
- Detector Temp is the TCD temperature. Standard operating temperature is 100°C. Refer to current vs temperature chart below to ensure that the bridge current and cell temperature are within the safe ranges for gases being tested.
- Reference and sample flows indicate actual flows in ccpm. Buttons below each field show the settings. Press the buttons to open a keyboard to change settings.
- Display units can be selected on the right-hand side. Selected units will appear throughout the program and the options included are ppm (impurity), % impurity, and % purity. Please note that you cannot calibrate with % purity selected.

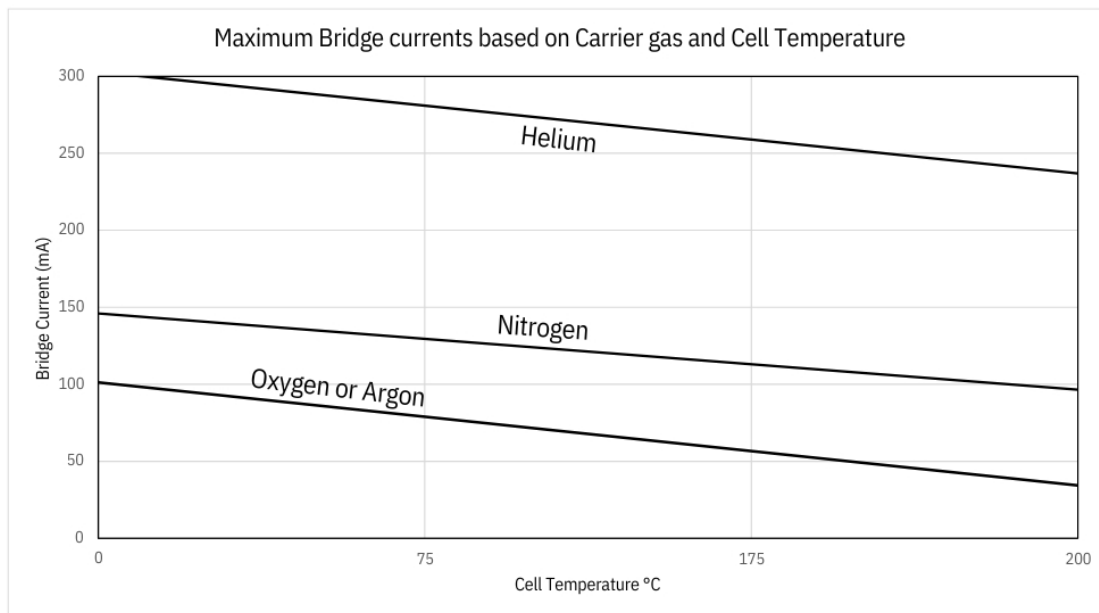

Maximum recommended bridge currents for pure gases, as determined by the gas's thermal conductivity. For binary mixes, maximum currents lie between the two curves for pure gases. This chart applies to TCDs with GOW-MAC W, WX, W2, AuW, and Ni filaments.

Detector. The detector signal is based on thermal conductivity of the flowing gases as well as the bridge current. The TCD is also very sensitive to temperature change. These variables must be controlled to minimize instrument output drift. The 5200 has a user-selectable feature where the current will self-adjust to correct drift. Further described in Section 5: Zero Interval.

Filament Fail-Safe. The 5200 has two fail-safe conditions disable detector bridge current. The purpose is to prevent energized filaments during conditions that would cause irreversible oxidation. First, the current will not turn on unless there is more than 10 ccpm for both sample and reference flows. When the instrument detects a significant flow decrease or if the flow shuts off completely, the current will automatically shut off and cannot be turned back on until the flows are restored and stable. Second, bridge current cannot be enabled until the detector temperature stabilizes at setpoint.



5. Control Screen features

- GAS buttons can be touched to manually select zero, span and sample gas to flow to the detector. Unselected gases do not flow because their manifold-mounted shutoff valves are closed.
- Zero Interval can be set to ensure the 5200 maintains its zero by correcting for baseline drift. This is enabled by pressing the “Zero Interval” button which turns green when enabled. The zeroing frequency is user-settable with an available range of 30 to 9999 minutes. The frequency is set by touching the minutes field (white box) entering the time in minutes, and then touching Enter.
- Ranges. There are 3 ranges to select. PPM (R1) for lowest concentrations, Low (R2) for lower percentage concentrations, and High (R3) for the highest impurity concentrations. There are no guidelines for range selection with the Series 5200 as every gas combination generates a different amount of signal. The range must be selected before calibration.
- The active range is displayed in the Status Bar as R1, R2, or R3.
- Polarity Button. If the instrument is displaying a negative signal, the polarity switch can be used to flip the signal in the positive direction.

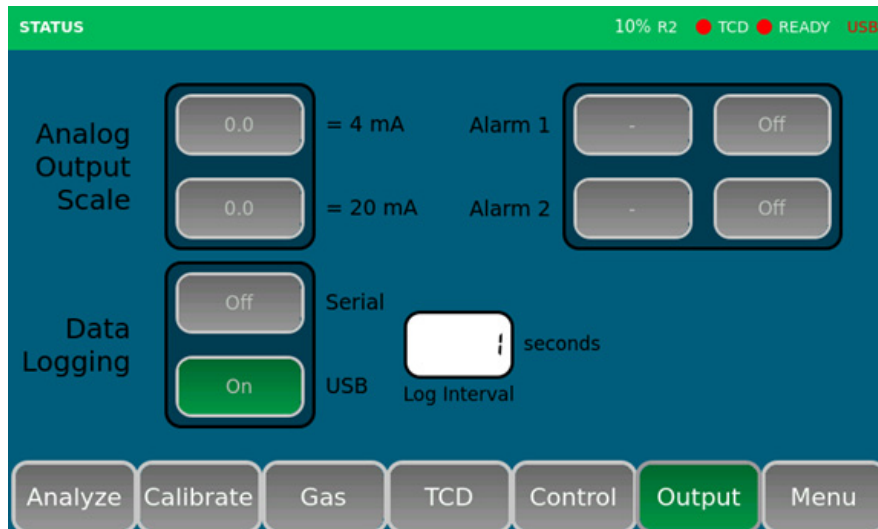

6. Output Screen features

- The values displayed on the output screen will reflect the selection made on the TCD page. For example, if you select “% Impurity”, the values on the output screen will be in % impurity.
- 4-20 mA Output. Enter the 4 to 20 mA output concentrations based on the desired range of measurement.
- Data Logging. Data logging is an option for users to collect data from the instrument while it is running. It can be collected either using USB or serial output and can be collected down to every second. The data collected while data logging is on includes the date, time, concentration (in selected display units – PPM I, % I, %P), and whether an alarm was triggered. When taking data on a USB, the USB must be plugged into a computer to access the files once logging is completed. The files will be in a .txt format. Use a USB drive with a single partition formatted to “FAT32”.
- Alarms. There are two alarms that can be set on the 5200; Alarm 1 and Alarm 2. Each have a Low and High value. The desired values can be entered and enabled by pressing the gray button beside each alarm. It will set to either low or high and can be reset by toggling the button. The active alarm is displayed in the Status bar as A1L (Alarm 1 Low), A1H (Alarm 1 High), A2L (Alarm 2 Low), and A2H (Alarm 2 High). When the alarm is triggered, these indicators will turn red, and a message will appear in the Status bar indicating the time the alarm was triggered. To turn off alarms, press the low/high buttons until they turn gray and indicate “off”.

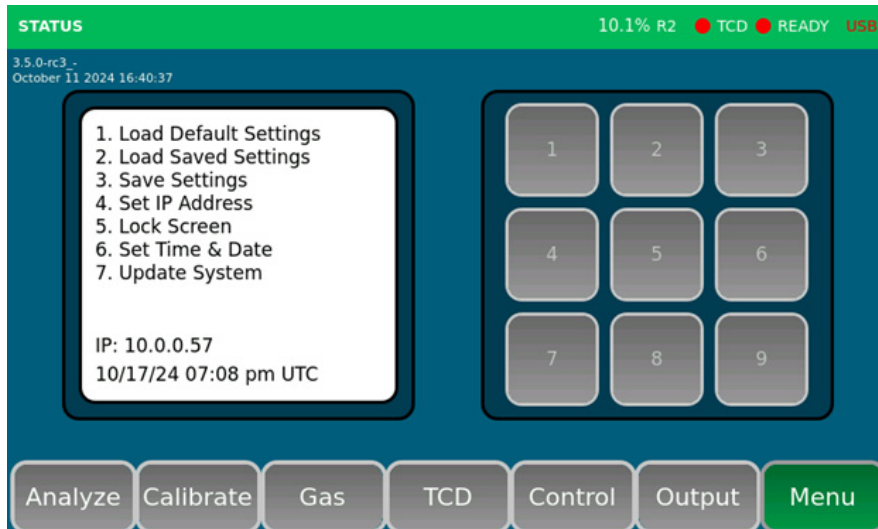

7. Menu Screen features

The MENU lists indexed actions that can be selected at any time. Select the action with a touch of the corresponding numbered key.

Menu Options:

1. **Load default settings.** Restores factory defaults.
2. **Load saved settings.** Loads last saved settings. Settings are saved on a successful calibration or when the Save Settings option is used.
3. **Save settings.** Saves the current operating settings.
4. **Set IP address.** If network cable is plugged in, the instrument will get the IP address from DHCP server on same subnet. Alternately, manually enter an IP address in format X.X.X.X.
5. **Lock screen.** Locks screen so only menu and analyze are available.
6. **Set Time and Date.** Allows the current date and time to be updated.
7. **Update system.** A software update to the Series 5200 can be installed via USB flash drive. Download the latest software on a flash drive. Use a USB drive with single partition formatted to "FAT32". Power off the 5200 at back panel power switch. Plug the drive into the USB port on the back of the instrument. Press key #7. A message in the Status Bar indicates the update is in progress. Follow prompt to reboot the system. The installed software revision is displayed on the Menu Screen after the reboot.

Section 7

Instrument Operation

1. Select gases on the Gas Screen.

a. Select sample gas.

i. This is the matrix gas of the sample, also described as the balance or main component of a gas mixture. The selected sample gas is communicated to a sample flow meter that corrects from a stored gas list. Sample flow readings on the TCD page are true provided the supplied gas matches the sample gas selected on the gas page.

b. Select reference gas.

i. This is the gas that will be flowing through the reference side of the TCD. For calibration, the reference gas is also called the “Zero” gas as it sets the zero point of the instrument.

2. **On the TCD screen**, set the TCD temperature to 100 °C. While the detector is heating, set reference and sample flows to 10-25 ccpm to avoid any damage to the filaments.

3. Once the detector has reached the steady state set temperature, increase flow for reference and sample gases. The suggested operating flow is 200 ccpm for the diffusion TCD especially while calibrating. Minimum flow for both channels is 50 ccpm during analysis (current ON), while maximum flow is 500 ccpm at any time. Setpoints of the flow will be stored in the instrument.

4. Please refer to the current vs temperature chart (in Section 6) to find bridge current within the safe range for the application. Press the “Current On/Off” button to turn the current on. In the upper right-hand corner, click the white box to set the current in milliamps (mA). Press “enter” to save the value. Observe a slow increase in the current. Once current reaches setpoint, allow instrument to stabilize for 4 – 5 hours.

The 5200 has fail-safe features to preserve the longevity of the TCD filaments. Once the current is on, gas flows cannot be set lower than 10 ccpm. The current will automatically turn off when there is a substantial decrease in either sample or reference gas flow or when the actual detector temperature is not at the setpoint. **The bridge current will be locked out until all setpoints are met.** The status bar will turn blue when the detector is ready for calibration.

5. On the Control screen:

a. Note that the raw signal in volts is displayed in the Signal field. The corresponding ppm or % value is shown on the Analyze screen and in the Status bar. The Ready light will only turn on when detector is on, instrument is calibrated, and the sample gas is selected and flowing.

b. Zero Interval can be used to set an interval for automatically resetting the signal to zero. The interval can be set for 30 – 99,999 minutes. Zero interval is turned on/off by toggling the button that says, “zero interval”. It will turn green when it is on and active, and it will be gray when turned off. Please note that while a zero interval is occurring, gases cannot be edited until the process is over.

- c. Range must be selected before calibrating to have successful calibration. To choose the correct range, select the zero gas in the left-hand corner and allow it to flow for a minute. Press “Signal Zero” to establish a zero point. Next select the Span gas and watch the signal. If the signal is below 0.200V, go down in range. If the signal bar is showing “OVER”, go up a range. If your signal is **Negative**, press the polarity button to flip it positive.

Note that available decimal places for displayed concentrations in ppm are related to the selected range. PPM(R1) shows two decimal places, LOW(R2) shows one, and HIGH(R3) shows no decimal places.

The selected range is indicated in the Status bar.

6. **Calibration** of the instrument is done on the Calibrate screen. Calibration sets the instrument zero and span reference points.

Allow up to an hour after current has been turned on for instrument signal to stabilize before calibrating. During calibration of zero and span gas, instrument outputs are unavailable.

- a. Zero must be performed first. Enter the actual level of impurities listed on the gas certification assay. If not known, enter 0.0 however the analysis accuracy will be off by the actual impurities in the zero gas. To enter a zero value, touch the field below the Zero button to open a keypad. Touch the zero button to initiate the zeroing process. The zero reference is set in each range. A stabilization bar will appear in the calibration message box to indicate the seconds left in calibration. When complete, the Status bar indicates completion of the zero process and its color changes to blue.
 - b. Span calibration is done next. The recommended span gas will exceed impurities than that of the sample, although based on application and concentration, the best span point can vary. Enter the total amount of impurities of the span gas by touching the field below the span button to open a keypad. Once entered, hit the span button which will then turn green, and the span process will begin. Again, a stabilization timer will appear in the calibration message box and upon successful calibration, the status bar will turn green, and the instrument is now ready to analyze. Date and time of the last successful calibration will appear in the status bar and in the calibration message box.
7. **Span Check.** To check validity of the span value at any point in the analysis, hit the check span button to initiate a span check process. The 5200 performs a verification of the saved span value. The span gas is sent to the detector and the resulting signal must be within 2% of the saved value to be considered good. A green light indicates a good span check, and a red light indicates that the checked value and the saved value differ by more than 2%. In this case, a new span should be performed.
 8. **Analyze.** Select the sample gas on the Control screen to analyze sample. Once selected, the ready light on the right side of the Status bar will turn red. Any gas (zero, sample, or span) can be analyzed at any time by selecting on the Control screen. The selected gas is indicated on the Analyze screen.

9. **Standby and Overnight Conditions.** The 5200 can be operated continuously. However, to conserve gas, the reference and sample flows can be lowered during an idle period and re-stored for the next analysis without a major effect on the calibration. Gas flows can be set as low as 10 ccpm while keeping the instrument purged and ready to quickly ramp up to an analysis-ready condition. Zero and span should be checked before analysis after an idle period. Ideally, the TCD temperature can be reduced to 80°C during an idle period. If leaving the 5200 with no gas flow, allow the detector to cool to below 80°C and shut down the instrument. This should be done to help preserve the life of the filaments.
10. **Shutdown Procedure.** As in standby and overnight description, shut down the current and the gas flows after allowing the TCD to cool down. Switch off the instrument power switch.

11. Daily Set-up Check List

- Gas supply/cylinder pressures adequate for the analysis session
- Detector temperature at steady state setting.
- Check zero and span and recalibrate if necessary.

Section 8

Troubleshooting

All Models

Not Calibrating. There are three known causes of a failure to calibrate the 5200. First, the instrument might not calibrate if set to the wrong range. Ensure the range is correct for the span gas. Second, the voltage signal shown on the control screen may be too low to calibrate. The threshold for a successful span calibration and good analysis is a signal of 0.24V or higher. Ensure that your span signal is greater than 0.24V. Lastly, if the span signal is negative, the polarity is wrong. Press the polarity switch on the Control screen to flip the signal. Fulfilling these conditions should allow for a successful calibration.

No bridge current. If your button for current displays as ON but there is no current, check all set points on the TCD screen. If any setpoint is not met (detector temperature or zero and sample flow) the detector current will automatically shut down. Check all gas pressures and connections to ensure specifications are being met and there are no leaks. Additionally, the TCD does take some time to equilibrate its temperature upon first power up. Please allow temperature to fully reach a steady state condition.

Unable to zero TCD. A reason for failure of the zero cycle is oxidized filaments. The 5200 is equipped with many failsafe protocols to avoid this from happening, although it is still possible by using too much current. Replacing the filaments is the only remedy if they are oxidized.

Section 9

Replacement Parts

<u>Description</u>	<u>Part Number</u>
Detector (Thermal Conductivity Detector).....	Contact GOW-MAC
Due to the variety of detector and filament options available, please contact GOW-MAC with the serial number of the instrument. The correct detector part will be determined. If the filaments are field-replaceable, the correct replacement filament quad part number will also be determined.	
Fuse, 10A, (115V).....	121-162
Fuse, 5A, (230V).....	121-177
+24V power supply, 2.2A (Instrument Serial No. LL74008 and below only).....	123-119
+24V Power Supply, 2.2A	123-138
Temp. Controller PCB, 2-chanel.....	123-310
Solid State Relay PCB, 2-channel.....	123-327-1
CPU Interface PCB.....	123-328
Detector PCB 5200.....	123-335-5-T
7" LCD Digital Touchscreen.....	123-341-2-P
Isolated 4-20mA Output PCB.....	123-357-T
Platinum probe for detector heater.....	124-175
Heater, 3/8 in OD X 3 in L, 100W, 120V.....	124-181
Heater, 3/8 in OD X 3 in L, 100W, 240V.....	124-182
Cord set, 115V, Detachable.....	127-378
Cord set, 230V, Detachable.....	127-407
DB25 Terminal Breakout.....	129-414
DB9 Terminal Breakout.....	129-440
DB9 Terminal Breakout Cover.....	129-441
DB25 Terminal Breakout Cover.....	129-442
7µm filter, 1/8" union, brass with stainless steel element.....	171-171

<u>Description</u>	<u>Part Number</u>
7µm filter, sintered element, stainless steel.....	171-174-7
7µm filter, 1/8" union, all stainless steel.....	171-247-7
Mass flow controller, 0-500 sccm	180-1010
Gas selection manifold shut-off valve.....	180-1032

Appendices

1. Error Message Glossary

Ready Error: Sample Gas. The sample gas is not flowing.

AmpEn Error: Current Not Ready. The current has not reached its setpoint or there has been a current shutoff condition.

Calibrate Error: Below Threshold. The signal for the span gas is too low for calibration.

Please Recalibrate Device. The span or zero value was changed, instrument must be recalibrated.

Please Recalibrate: Below Threshold. The zero has drifted in the negative direction or the polarity is set incorrectly.

2. Default gas flows and currents.

Recommended flow rates for the 5200 are 200 ccpm for both reference and sample gas. These flow rates are essential for an accurate calculation. Please refer to GOW-MAC's General Service Bulletin to get more information on choosing a safe current for your analysis.

3. Drawings and Schematics

Model 5200, 115VAC, 60 Hz

Flow Diagram A-22741

Electrical Schematic C-22742

Model 5202, 230VAC, 50 Hz

Flow Diagram A-22741

Electrical Schematic C-22742

Warranty

ALL INSTRUMENTS SOLD BY GOW-MAC® INSTRUMENT CO. ARE WARRANTED FOR A PERIOD OF ONE YEAR AGAINST DEFECTS IN MATERIALS AND WORKMANSHIP. THE TERMS OF THIS WARRANTY ARE AS FOLLOWS:

1. **The warranty period begins with the shipping date of the equipment to the original purchaser.**
2. Certain parts such as batteries, fuses, glass accessories, septa, columns, etc., are expendable in normal use, and their service life is unpredictable. Such items are not covered by this warranty.
3. Filaments of thermal conductivity detectors are not covered by this warranty.
4. Hydrogen Palladium Tubes are not covered by this warranty.
5. All requests for service or repair under this warranty must be received within the warranty period by GOW-MAC® or its authorized representative. All repairs are made at GOW-MAC plants or at the office of authorized representatives.
6. All repairs, adjustments, and other services under this warranty shall be performed free of charge to the purchaser. However, warranty service and repairs shall be limited to equipment malfunctions which, in the opinion of GOW-MAC®, are due or traceable to defects in original materials or workmanship. Instrument malfunctions caused by abuse or neglect of the equipment are expressly not covered by this warranty.
7. Instrument parts which have been repaired or replaced during the warranty period are themselves warranted only for the remaining unexpired portion of the original one-year warranty.
8. Repairs, adjustments, and service performed after expiration of the one-year warranty period shall be charged to the purchaser at the then current prices for parts, labor, and transportation.
9. This warranty attaches to the equipment itself and is not limited to the original purchaser. Unexpired portions of the warranty are thus transferable to subsequent owners.
10. GOW-MAC® expressly disclaims any liability to users of its products for consequential damages of any kind arising out of or connected with the use of its products.
11. Except as stated in Sections 1 through 8 above, GOW-MAC® makes no warranty, expressed or implied (either in fact or by operation of law), statutory or otherwise; and, except as stated in Sections 1 through 8 above, GOW-MAC® shall have no liability under any warranty, expressed or implied (either in fact or by operation of law), statutory or otherwise.
12. Statements made by any person, including representatives of GOW-MAC® which are inconsistent or in conflict with the terms of this warranty shall not be binding upon GOW-MAC® unless reduced to writing and approved by an officer of the Company.
13. This warranty shall be governed by the laws of the Commonwealth of Pennsylvania.

7/8/24
kj

Health and Safety Declaration for the Return of GOW-MAC Instrument Co. Equipment

In order to protect our employees from exposure to various hazards, the following statements and/or questions **MUST** be answered by you. Fill out this document in its entirety and either fax or e-mail it to GOW-MAC Instrument Co., Attn: Repair Dept, **BEFORE** returning the product.

The instrument/part being returned **will not** be accepted into GOW-MAC's facility until we receive this completed document, along with a **PO or Credit Card**. Once approved for return by our Chemical Safety Officer, a **Return Materials Authorization (RMA) number** and shipping instructions will be issued. *All applicable regulations should be followed when returning instrumentation, and/or parts.*

Customer to Record the Following:

Model # / Part # _____
 Serial #: _____
 Service Technician spoken to: _____
 Today's Date: _____

IF THIS FORM IS NOT APPROVED BY OUR CHEMICAL SAFETY OFFICER, THE INSTRUMENT/PART WILL NOT BE PERMITTED INTO OUR FACILITY FOR SERVICING!

- A) Brief explanation of issue: _____
 B) Briefly list the application(s) for which the instrument/part was used, as well as any and all chemicals, gases, and/or materials analyzed and their concentrations. (**Must be filled in**): _____
 C) Is there the possibility of internal or external contamination on or in this instrument/part?
 Yes – see below No – proceed to D.

Please check the appropriate box.

- Chemicals or Substances That Are Hazardous to Health
- Blood, Body Fluids, (e.g. Urine, Secretions), Pathological Specimens
- Regulated Medical Wastes
- Infectious Substances or other Bio-Agents (e.g. Protein, Enzymes, Antibodies)
- Radioactive Isotopes used in the area. Detail type (ECD, Isotopic Labels, etc) and Activity in Micro Curies
- Biodegradable Material That Could Become Hazardous
- Other Hazards _____

If any of the above boxes are checked the following statements and/or questions must be answered.

1. Specifically describe where (on or in) the instrument/part there could be any residual contamination (for example: blood spill on the surface). _____

2. Provide details of these hazards. Include names, Material Safety Data Sheets (MSDS), and concentration of contaminants, where possible. _____

3. Describe the method of decontamination used. Attach Procedure. _____

- D) I declare that the above information is true and complete to the best of my knowledge. I acknowledge that any inconsistencies between the condition of the instrument and the statements made on this form will delay the repair process.

Authorized signature _____ Date: _____

Name (Printed) _____ Phone number: _____

Company name: _____ Fax number: _____

Shipping address: _____

City: _____ State/Country: _____ Zip: _____

E-mail address: _____

BEFORE item can be shipped, fax completed form to: (610) 954-0599 or e-mail it to: repairs@gow-mac.com

For GOW-MAC Use Only:	Signed: _____	Date ____/____/____
<input type="checkbox"/> Passed Safety Inspection. OK to proceed to Repair Dept.	Chemical Safety Officer	Comments: () None
<input type="checkbox"/> Failed safety Inspection. DO NOT proceed to Repair Dept.	RMA No: _____	() On Back >>>>

REP-005
 Health-Safety Declaration Doc – ONLINE
 Rev.7 1/28/2022, kj



